



Dell™ PowerConnect™ J-Series J-SRX240 Services Gateway

Hardware Guide



Published: 2010-06-07

Dell
501 Dell Way
Round Rock, Texas 78682
United States
www.dell.com

This product includes the Envoy SNMP Engine, developed by Epilogue Technology, an Integrated Systems Company. Copyright © 1986-1997, Epilogue Technology Corporation. All rights reserved. This program and its documentation were developed at private expense, and no part of them is in the public domain.

This product includes memory allocation software developed by Mark Moraes, copyright © 1988, 1989, 1993, University of Toronto.

This product includes FreeBSD software developed by the University of California, Berkeley, and its contributors. All of the documentation and software included in the 4.4BSD and 4.4BSD-Lite Releases is copyrighted by the Regents of the University of California. Copyright © 1979, 1980, 1983, 1986, 1988, 1989, 1991, 1992, 1993, 1994. The Regents of the University of California. All rights reserved.

GateD software copyright © 1995, the Regents of the University. All rights reserved. Gate Daemon was originated and developed through release 3.0 by Cornell University and its collaborators. GateD is based on Kirton's EGP, UC Berkeley's routing daemon (routed), and DCN's HELLO routing protocol. Development of GateD has been supported in part by the National Science Foundation. Portions of the GateD software copyright © 1988, Regents of the University of California. All rights reserved. Portions of the GateD software copyright © 1991, D. L. S. Associates.

This product includes software developed by Maker Communications, Inc., copyright © 1996, 1997, Maker Communications, Inc.

Information in this document is subject to change without notice. All rights reserved. Reproduction of these materials in any manner whatsoever without the written permission of Dell, Inc. is strictly forbidden. Trademarks used in this text: Dell, the DELL logo, and PowerConnect are trademarks of Dell Inc.

Juniper Networks, the Juniper Networks logo, JUNOS, NetScreen, ScreenOS, and Steel-Belted Radius are registered trademarks of Juniper Networks, Inc. in the United States and other countries. JUNOSe is a trademark of Juniper Networks, Inc.

All other trademarks, service marks, registered trademarks, or registered service marks are the property of their respective owners.

Juniper Networks assumes no responsibility for any inaccuracies in this document. Juniper Networks reserves the right to change, modify, transfer, or otherwise revise this publication without notice.

Products made or sold by Juniper Networks or components thereof might be covered by one or more of the following patents that are owned by or licensed to Juniper Networks: U.S. Patent Nos. 5,473,599, 5,905,725, 5,909,440, 6,192,051, 6,333,650, 6,359,479, 6,406,312, 6,429,706, 6,459,579, 6,493,347, 6,538,518, 6,538,899, 6,552,918, 6,567,902, 6,578,186, and 6,590,785.

J-SRX240 Services Gateway Hardware Guide
© Copyright Dell, Inc., 2010. All rights reserved.

Revision History
July 2010 — Revision 01

The information in this document is current as of the date listed in the revision history.

SOFTWARE LICENSE

The terms and conditions for using this software are described in the software license contained in the acknowledgment to your purchase order or, to the extent applicable, to any reseller agreement or end-user purchase agreement executed between you and Juniper Networks. By using this software, you indicate that you understand and agree to be bound by those terms and conditions.

Generally speaking, the software license restricts the manner in which you are permitted to use the software and may contain prohibitions against certain uses. The software license may state conditions under which the license is automatically terminated. You should consult the license for further details.

For complete product documentation, please see the Juniper Networks Web site at www.juniper.net/techpubs.

END USER LICENSE AGREEMENT

READ THIS END USER LICENSE AGREEMENT (“AGREEMENT”) BEFORE DOWNLOADING, INSTALLING, OR USING THE SOFTWARE. BY DOWNLOADING, INSTALLING, OR USING THE SOFTWARE OR OTHERWISE EXPRESSING YOUR AGREEMENT TO THE TERMS CONTAINED HEREIN, YOU (AS CUSTOMER OR IF YOU ARE NOT THE CUSTOMER, AS A REPRESENTATIVE/AGENT AUTHORIZED TO BIND THE CUSTOMER) CONSENT TO BE BOUND BY THIS AGREEMENT. IF YOU DO NOT OR CANNOT AGREE TO THE TERMS CONTAINED HEREIN, THEN (A) DO NOT DOWNLOAD, INSTALL, OR USE THE SOFTWARE, AND (B) YOU MAY CONTACT JUNIPER NETWORKS REGARDING LICENSE TERMS.

1. **The Parties.** The parties to this Agreement are (i) Juniper Networks, Inc. (if the Customer’s principal office is located in the Americas) or Juniper Networks (Cayman) Limited (if the Customer’s principal office is located outside the Americas) (such applicable entity being referred to herein as “Juniper”), and (ii) the person or organization that originally purchased from Juniper or an authorized Juniper reseller the applicable license(s) for use of the Software (“Customer”) (collectively, the “Parties”).
2. **The Software.** In this Agreement, “Software” means the program modules and features of the Juniper or Juniper-supplied software, for which Customer has paid the applicable license or support fees to Juniper or an authorized Juniper reseller, or which was embedded by Juniper in equipment which Customer purchased from Juniper or an authorized Juniper reseller. “Software” also includes updates, upgrades and new releases of such software. “Embedded Software” means Software which Juniper has embedded in or loaded onto the Juniper equipment and any updates, upgrades, additions or replacements which are subsequently embedded in or loaded onto the equipment.
3. **License Grant.** Subject to payment of the applicable fees and the limitations and restrictions set forth herein, Juniper grants to Customer a non-exclusive and non-transferable license, without right to sublicense, to use the Software, in executable form only, subject to the following use restrictions:
 - a. Customer shall use Embedded Software solely as embedded in, and for execution on, Juniper equipment originally purchased by Customer from Juniper or an authorized Juniper reseller.
 - b. Customer shall use the Software on a single hardware chassis having a single processing unit, or as many chassis or processing units for which Customer has paid the applicable license fees; provided, however, with respect to the Steel-Belted Radius or Odyssey Access Client software only, Customer shall use such Software on a single computer containing a single physical random access memory space and containing any number of processors. Use of the Steel-Belted Radius or IMS AAA software on multiple computers or virtual machines (e.g., Solaris zones) requires multiple licenses, regardless of whether such computers or virtualizations are physically contained on a single chassis.
 - c. Product purchase documents, paper or electronic user documentation, and/or the particular licenses purchased by Customer may specify limits to Customer’s use of the Software. Such limits may restrict use to a maximum number of seats, registered endpoints, concurrent users, sessions, calls, connections, subscribers, clusters, nodes, realms, devices, links, ports or transactions, or require the purchase of separate licenses to use particular features, functionalities, services, applications, operations, or capabilities, or provide throughput, performance, configuration, bandwidth, interface, processing, temporal, or geographical limits. In addition, such limits may restrict the use of the Software to managing certain kinds of networks or require the Software to be used only in conjunction with other specific Software. Customer’s use of the Software shall be subject to all such limitations and purchase of all applicable licenses.
 - d. For any trial copy of the Software, Customer’s right to use the Software expires 30 days after download, installation or use of the Software. Customer may operate the Software after the 30-day trial period only if Customer pays for a license to do so. Customer may not extend or create an additional trial period by re-installing the Software after the 30-day trial period.
 - e. The Global Enterprise Edition of the Steel-Belted Radius software may be used by Customer only to manage access to Customer’s enterprise network. Specifically, service provider customers are expressly prohibited from using the Global Enterprise Edition of the Steel-Belted Radius software to support any commercial network access services.

The foregoing license is not transferable or assignable by Customer. No license is granted herein to any user who did not originally purchase the applicable license(s) for the Software from Juniper or an authorized Juniper reseller.

4. **Use Prohibitions.** Notwithstanding the foregoing, the license provided herein does not permit the Customer to, and Customer agrees not to and shall not: (a) modify, unbundle, reverse engineer, or create derivative works based on the Software; (b) make unauthorized copies of the Software (except as necessary for backup purposes); (c) rent, sell, transfer, or grant any rights in and to any copy of the Software, in any form, to any third party; (d) remove any proprietary notices, labels, or marks on or in any copy of the Software or any product in which the Software is embedded; (e) distribute any copy of the Software to any third party, including as may be embedded in Juniper equipment sold in the secondhand market; (f) use any ‘locked’ or key-restricted feature, function, service, application, operation, or capability without first purchasing the applicable license(s) and obtaining a valid key from Juniper, even if such feature, function, service, application, operation, or capability is enabled without a key; (g) distribute any key for the Software provided by Juniper to any third party; (h) use the

Software in any manner that extends or is broader than the uses purchased by Customer from Juniper or an authorized Juniper reseller; (i) use Embedded Software on non-Juniper equipment; (j) use Embedded Software (or make it available for use) on Juniper equipment that the Customer did not originally purchase from Juniper or an authorized Juniper reseller; (k) disclose the results of testing or benchmarking of the Software to any third party without the prior written consent of Juniper; or (l) use the Software in any manner other than as expressly provided herein.

5. **Audit.** Customer shall maintain accurate records as necessary to verify compliance with this Agreement. Upon request by Juniper, Customer shall furnish such records to Juniper and certify its compliance with this Agreement.

6. **Confidentiality.** The Parties agree that aspects of the Software and associated documentation are the confidential property of Juniper. As such, Customer shall exercise all reasonable commercial efforts to maintain the Software and associated documentation in confidence, which at a minimum includes restricting access to the Software to Customer employees and contractors having a need to use the Software for Customer's internal business purposes.

7. **Ownership.** Juniper and Juniper's licensors, respectively, retain ownership of all right, title, and interest (including copyright) in and to the Software, associated documentation, and all copies of the Software. Nothing in this Agreement constitutes a transfer or conveyance of any right, title, or interest in the Software or associated documentation, or a sale of the Software, associated documentation, or copies of the Software.

8. **Warranty, Limitation of Liability, Disclaimer of Warranty.** The warranty applicable to the Software shall be as set forth in the warranty statement that accompanies the Software (the "Warranty Statement"). Nothing in this Agreement shall give rise to any obligation to support the Software. Support services may be purchased separately. Any such support shall be governed by a separate, written support services agreement. TO THE MAXIMUM EXTENT PERMITTED BY LAW, JUNIPER SHALL NOT BE LIABLE FOR ANY LOST PROFITS, LOSS OF DATA, OR COSTS OR PROCUREMENT OF SUBSTITUTE GOODS OR SERVICES, OR FOR ANY SPECIAL, INDIRECT, OR CONSEQUENTIAL DAMAGES ARISING OUT OF THIS AGREEMENT, THE SOFTWARE, OR ANY JUNIPER OR JUNIPER-SUPPLIED SOFTWARE. IN NO EVENT SHALL JUNIPER BE LIABLE FOR DAMAGES ARISING FROM UNAUTHORIZED OR IMPROPER USE OF ANY JUNIPER OR JUNIPER-SUPPLIED SOFTWARE. EXCEPT AS EXPRESSLY PROVIDED IN THE WARRANTY STATEMENT TO THE EXTENT PERMITTED BY LAW, JUNIPER DISCLAIMS ANY AND ALL WARRANTIES IN AND TO THE SOFTWARE (WHETHER EXPRESS, IMPLIED, STATUTORY, OR OTHERWISE), INCLUDING ANY IMPLIED WARRANTY OF MERCHANTABILITY, FITNESS FOR A PARTICULAR PURPOSE, OR NONINFRINGEMENT. IN NO EVENT DOES JUNIPER WARRANT THAT THE SOFTWARE, OR ANY EQUIPMENT OR NETWORK RUNNING THE SOFTWARE, WILL OPERATE WITHOUT ERROR OR INTERRUPTION, OR WILL BE FREE OF VULNERABILITY TO INTRUSION OR ATTACK. In no event shall Juniper's or its suppliers' or licensors' liability to Customer, whether in contract, tort (including negligence), breach of warranty, or otherwise, exceed the price paid by Customer for the Software that gave rise to the claim, or if the Software is embedded in another Juniper product, the price paid by Customer for such other product. Customer acknowledges and agrees that Juniper has set its prices and entered into this Agreement in reliance upon the disclaimers of warranty and the limitations of liability set forth herein, that the same reflect an allocation of risk between the Parties (including the risk that a contract remedy may fail of its essential purpose and cause consequential loss), and that the same form an essential basis of the bargain between the Parties.

9. **Termination.** Any breach of this Agreement or failure by Customer to pay any applicable fees due shall result in automatic termination of the license granted herein. Upon such termination, Customer shall destroy or return to Juniper all copies of the Software and related documentation in Customer's possession or control.

10. **Taxes.** All license fees payable under this agreement are exclusive of tax. Customer shall be responsible for paying Taxes arising from the purchase of the license, or importation or use of the Software. If applicable, valid exemption documentation for each taxing jurisdiction shall be provided to Juniper prior to invoicing, and Customer shall promptly notify Juniper if their exemption is revoked or modified. All payments made by Customer shall be net of any applicable withholding tax. Customer will provide reasonable assistance to Juniper in connection with such withholding taxes by promptly: providing Juniper with valid tax receipts and other required documentation showing Customer's payment of any withholding taxes; completing appropriate applications that would reduce the amount of withholding tax to be paid; and notifying and assisting Juniper in any audit or tax proceeding related to transactions hereunder. Customer shall comply with all applicable tax laws and regulations, and Customer will promptly pay or reimburse Juniper for all costs and damages related to any liability incurred by Juniper as a result of Customer's non-compliance or delay with its responsibilities herein. Customer's obligations under this Section shall survive termination or expiration of this Agreement.

11. **Export.** Customer agrees to comply with all applicable export laws and restrictions and regulations of any United States and any applicable foreign agency or authority, and not to export or re-export the Software or any direct product thereof in violation of any such restrictions, laws or regulations, or without all necessary approvals. Customer shall be liable for any such violations. The version of the Software supplied to Customer may contain encryption or other capabilities restricting Customer's ability to export the Software without an export license.

12. **Commercial Computer Software.** The Software is "commercial computer software" and is provided with restricted rights. Use, duplication, or disclosure by the United States government is subject to restrictions set forth in this Agreement and as provided in DFARS 227.7201 through 227.7202-4, FAR 12.212, FAR 27.405(b)(2), FAR 52.227-19, or FAR 52.227-14 (ALT III) as applicable.

13. **Interface Information.** To the extent required by applicable law, and at Customer's written request, Juniper shall provide Customer with the interface information needed to achieve interoperability between the Software and another independently created program, on payment of applicable fee, if any. Customer shall observe strict obligations of confidentiality with respect to such information and shall use such information in compliance with any applicable terms and conditions upon which Juniper makes such information available.

14. **Third Party Software.** Any licensor of Juniper whose software is embedded in the Software and any supplier of Juniper whose products or technology are embedded in (or services are accessed by) the Software shall be a third party beneficiary with respect to this Agreement, and such licensor or vendor shall have the right to enforce this Agreement in its own name as if it were Juniper. In addition, certain third party software may be provided with the Software and is subject to the accompanying license(s), if any, of its respective owner(s). To the extent portions of the Software are distributed under and subject to open source licenses obligating Juniper to make the source code for such portions publicly available (such as the GNU General Public License ("GPL") or the GNU Library General Public License ("LGPL")), Juniper will make such source code portions (including Juniper modifications, as appropriate) available upon request for a period of up to three years from the date of distribution. Such request can be made in writing to Juniper Networks, Inc., 1194 N. Mathilda Ave., Sunnyvale, CA 94089, ATTN: General Counsel. You may obtain a copy of the GPL at <http://www.gnu.org/licenses/gpl.html>, and a copy of the LGPL at <http://www.gnu.org/licenses/lgpl.html>.

15. **Miscellaneous.** This Agreement shall be governed by the laws of the State of California without reference to its conflicts of laws principles. The provisions of the U.N. Convention for the International Sale of Goods shall not apply to this Agreement. For any disputes arising under this Agreement, the Parties hereby consent to the personal and exclusive jurisdiction of, and venue in, the state and federal courts within Santa Clara County, California. This Agreement constitutes the entire and sole agreement between Juniper and the Customer with respect to the Software, and supersedes all prior and contemporaneous agreements relating to the Software, whether oral or written (including any inconsistent terms contained in a purchase order), except that the terms of a separate written agreement executed by an authorized Juniper representative and Customer shall govern to the extent such terms are inconsistent or conflict with terms contained herein. No modification to this Agreement nor any waiver of any rights hereunder shall be effective unless expressly assented to in writing by the party to be charged. If any portion of this Agreement is held invalid, the Parties agree that such invalidity shall not affect the validity of the remainder of this Agreement. This Agreement and associated documentation has been written in the English language, and the Parties agree that the English version will govern. (For Canada: Les parties aux présentes confirment leur volonté que cette convention de même que tous les documents y compris tout avis qui s'y rattache, soient rédigés en langue anglaise. (Translation: The parties confirm that this Agreement and all related documentation is and will be in the English language)).

Table of Contents

	About This Guide	xiii
	Objectives	xiii
	Audience	xiii
	Documentation Conventions	xiii
	Repair and Warranty	xv
	Requesting Technical Support	xv
Part 1	J-SRX240 Services Gateway Overview	
Chapter 1	Introduction to the J-SRX240 Services Gateway	3
	J-SRX240 Services Gateway Description	3
	About the J-SRX240 Services Gateway	3
	J-SRX240 Services Gateway Models	3
	Accessing the J-SRX240 Services Gateway	4
	J-SRX240 Services Gateway Hardware Features	4
Chapter 2	J-SRX240 Services Gateway Hardware Components and Specifications	7
	J-SRX240 Services Gateway Specifications	7
	J-SRX240 Services Gateway Front Panel and Back Panel Views	9
	J-SRX240 Services Gateway Front Panel (High Memory and Low Memory)	9
	J-SRX240 Services Gateway Back Panel (PoE, High Memory, and Low Memory)	11
	J-SRX240 Services Gateway with Integrated Convergence Services Front Panel and Back Panel Views	11
	J-SRX240 Services Gateway with Integrated Convergence Services Front Panel	12
	J-SRX240 Services Gateway with Integrated Convergence Services Back Panel	12
	J-SRX240 Services Gateway Built-In Interfaces	13
	J-SRX240 Services Gateway LEDs	14
	Front Panel LEDs	14
	Ethernet Port LEDs	16
	Voice Interface Port LED	17
	J-SRX240 Services Gateway Boot Devices and Dual-Root Partitioning Scheme	19
	Boot Devices	19
	Dual-Root Partitioning Scheme	19
	J-SRX240 Services Gateway Power Supply	20
	J-SRX240 Services Gateway Cooling System	20

Chapter 3	J-SRX240 Services Gateway Mini-Physical Interface Modules 23
	Mini-Physical Interface Modules on the J-SRX240 Services Gateway 23
Chapter 4	J-SRX240 Services Gateway Power over Ethernet Support 25
	J-SRX240 Services Gateway Power over Ethernet Overview 25
	Introduction 25
	PoE Classes and Power Ratings 26
	Configuring PoE Functionality on the J-SRX240 Services Gateway 26
Chapter 5	J-SRX240 Services Gateway with Integrated Convergence Services 29
	Introducing the J-SRX240 Services Gateway with Integrated Convergence
	Services 29
	Features and Functions 29
	Basic Functions 30
	Common Deployment Scenarios 30
	Understanding the Functions of the J-SRX240 Services Gateway with Integrated
	Convergence Services 31
	J-SRX240 Services Gateway with Integrated Convergence Services
	Interoperability 31
	Configuring the J-SRX240 Services Gateway with Integrated Convergence
	Services 32
Part 2	Setting Up the J-SRX240 Services Gateway
Chapter 6	Preparing the Site for the J-SRX240 Services Gateway Installation 37
	Site Preparation Checklist for the J-SRX240 Services Gateway 37
	General Site Guidelines for Installing the J-SRX240 Services Gateway 38
	J-SRX240 Services Gateway Rack Requirements 39
	Clearance Requirements for Airflow and Hardware Maintenance on the J-SRX240
	Services Gateway 40
	J-SRX240 Services Gateway Electrical and Power Requirements 41
	J-SRX240 Services Gateway Network Cable Requirements and
	Specifications 41
Chapter 7	Installation Overview for the J-SRX240 Services Gateway 43
	Installation Overview for the J-SRX240 Services Gateway 44
Chapter 8	Required Tools and Parts for Installing and Maintaining the J-SRX240
	Services Gateway 45
	Required Tools and Parts for Installing and Maintaining the J-SRX240 Services
	Gateway 45
Chapter 9	Unpacking the J-SRX240 Services Gateway 47
	Unpacking the J-SRX240 Services Gateway 47
	Verifying Parts Received with the J-SRX240 Services Gateway 47
Chapter 10	Installing the J-SRX240 Services Gateway 51
	J-SRX240 Services Gateway Safety Requirements, Warnings, and
	Guidelines 51
	Preparing the J-SRX240 Services Gateway for Installation 51
	Installing the J-SRX240 Services Gateway 52

	Replacing or Installing Mini-Physical Interface Modules in the J-SRX240 Services Gateway	54
Chapter 11	Connecting, Grounding, and Powering On the J-SRX240 Services Gateway	55
	Connecting the J-SRX240 Services Gateway to the Power Supply	55
	Connecting and Organizing Interface Cables to the J-SRX240 Services Gateway	56
	Grounding the J-SRX240 Services Gateway	57
	Powering On and Powering Off the J-SRX240 Services Gateway	59
	Powering On the J-SRX240 Services Gateway	59
	Powering Off the J-SRX240 Services Gateway	59
Chapter 12	J-SRX240 Services Gateway Autoinstallation	61
	J-SRX240 Services Gateway Autoinstallation Overview	61
Chapter 13	Connecting the J-SRX240 Services Gateway to Management Devices . . .	63
	Connecting the J-SRX240 Services Gateway to the J-Web Interface	63
	Connecting the J-SRX240 Services Gateway to the CLI	66
	Connecting the Modem at the J-SRX240 Services Gateway End	68
	Connecting the Modem to the Console Port on the J-SRX240 Services Gateway	69
	Connecting to the CLI at the User End for the J-SRX240 Services Gateway	69
Chapter 14	Performing Initial Software Configuration on the J-SRX240 Services Gateway	71
	J-SRX240 Services Gateway Software Configuration Overview	71
	Preparing J-SRX240 Services Gateway for Configuration	71
	Understanding Built-In Ethernet Ports	72
	Mapping the Chassis Cluster Ports	72
	Understanding Management Access	73
	Performing Initial Software Configuration on the J-SRX240 Services Gateway Using the CLI	74
	Performing Initial Software Configuration on the J-SRX240 Services Gateway Using the J-Web Interface	76
	Establishing Basic Connectivity	77
	Configuring Basic System Properties	78
	J-SRX240 Services Gateway Secure Web Access Overview	82
Part 3	Maintaining, Replacing, and Monitoring the J-SRX240 Services Gateway Hardware	
Chapter 15	Maintaining the J-SRX240 Services Gateway Hardware Components . . .	85
	Maintaining the J-SRX240 Services Gateway Hardware Components	85
Chapter 16	Monitoring the J-SRX240 Services Gateway	87
	Monitoring Hardware Components on the J-SRX240 Services Gateway	87
	Monitoring the J-SRX240 Services Gateway Chassis Using the CLI	87
	Monitoring the J-SRX240 Services Gateway Components Using LEDs	89
	Monitoring the J-SRX240 Services Gateway Using Chassis Alarm Conditions	92

Monitoring the J-SRX240 Services Gateway Power System	93
Resetting the Configuration File When the J-SRX240 Services Gateway Is Inaccessible	94
Using the Reset Config Button on the J-SRX240 Services Gateway	94
Changing the Reset Config Button Behavior on the J-SRX240 Services Gateway	95
Dell Support	96

Part 4

Appendixes

Appendix A

Safety and Regulatory Compliance Information 99

J-SRX240 Services Gateway Definition of Safety Warning Levels	99
J-SRX240 Services Gateway General Safety Guidelines and Warnings	101
J-SRX240 Services Gateway Fire Safety Requirements	105
J-SRX240 Services Gateway Installation Safety Guidelines and Warnings	106
J-SRX240 Services Gateway Laser and LED Safety Guidelines and Warnings	110
Laser and LED Safety Guidelines and Warnings	110
General Laser Safety Guidelines	110
Class 1 Laser Product Warning	111
Class 1 LED Product Warning	111
Laser Beam Warning	111
Radiation from Open Port Apertures Warning	112
J-SRX240 Services Gateway Maintenance and Operational Safety Guidelines and Warnings	113
Safety Guidelines and Warnings	113
Battery Handling Warning	113
Jewelry Removal Warning	114
Lightning Activity Warning	115
Operating Temperature Warning	116
Product Disposal Warning	117
J-SRX240 Services Gateway Electrical Safety Guidelines and Warnings	118
Electrical Safety Guidelines and Warnings	118
In Case of Electrical Accident	118
General Electrical Safety Guidelines and Warnings	118
J-SRX240 Services Gateway Agency Approvals	119
J-SRX240 Services Gateway Compliance Statements for EMC Requirements	120
Canada	121
European Community	121
Japan	121
United States	121
J-SRX240 Services Gateway Compliance Statements for Environmental Requirements	121
J-SRX240 Services Gateway Compliance Statements for Acoustic Noise	122

Appendix B

**J-SRX240 Services Gateway Power Guidelines, Requirements, and
Specifications 123**

J-SRX240 Services Gateway Site Electrical Wiring Guidelines	123
J-SRX240 Services Gateway Power Specifications and Requirements	124
J-SRX240 Services Gateway Grounding Specifications	125

Appendix C	J-SRX240 Services Gateway Interface Cable Specifications and Connector Pinouts	127
	Interface Cable and Wire Specifications for the J-SRX240 Services Gateway . . .	127
	RJ-45 Connector Pinouts for the J-SRX240 Services Gateway Ethernet Port . . .	128
	RJ-45 Connector Pinouts for the J-SRX240 Services Gateway Console Port . . .	128
	RJ-11 Connector Pinouts for the J-SRX240 Services Gateway with Integrated Convergence Services FXO and FXS Ports	129
Appendix D	Getting Help	131
	Obtaining Assistance	131
	Online Services	132
	Automated Order-Status Service	133
	Support Service	133
	Dell Enterprise Training and Certification	133
	Problems With Your Order	133
	Product Information	133
	Returning Items for Warranty Repair or Credit	133
	Before You Call	134
	Diagnostics Checklist	134
	Contacting Dell	135
	Locating a J-SRX240 Services Gateway Component Serial Number and Agency Labels	135
	Packing the J-SRX240 Services Gateway and Components for Shipment	136
	Dell Support	138
Part 5	Index	
	Index	141

About This Guide

- Objectives on page xiii
- Audience on page xiii
- Documentation Conventions on page xiii
- Repair and Warranty on page xv
- Requesting Technical Support on page xv

Objectives

This guide describes hardware components and installation, basic configuration, and basic troubleshooting procedures for the PowerConnect™ J-Series J-SRX240 Services Gateway. It explains how to prepare your site for services gateway installation, unpack and install the hardware, power on the services gateway, perform initial software configuration, and perform routine maintenance. After completing the installation and basic configuration procedures covered in this guide, see the JUNOS Software configuration guides for information about further JUNOS Software configuration.

Audience

This guide is designed for network administrators who are installing and maintaining a J-SRX240 Services Gateway or preparing a site for device installation. To use this guide, you need a broad understanding of networks in general and the Internet in particular, networking principles, and network configuration. Any detailed discussion of these concepts is beyond the scope of this guide.

Documentation Conventions

Table 1: Notice Icons





Icon	Meaning	Description
	Informational note	Indicates important features or instructions.
	Caution	Indicates a situation that might result in loss of data or hardware damage.
	Warning	Alerts you to the risk of personal injury or death.
	Laser warning	Alerts you to the risk of personal injury from a laser.

Table 2: Text and Syntax Conventions

Convention	Description	Examples
Bold text like this	Represents text that you type.	To enter configuration mode, type the configure command: user@host> configure
Fixed-width text like this	Represents output that appears on the terminal screen.	user@host> show chassis alarms No alarms currently active
<i>Italic text like this</i>	<ul style="list-style-type: none"> Introduces important new terms. Identifies book names. Identifies RFC and Internet draft titles. 	<ul style="list-style-type: none"> A policy <i>term</i> is a named structure that defines match conditions and actions. <i>JUNOS Software System Basics Configuration Guide</i> RFC 1997, <i>BGP Communities Attribute</i>
<i>Italic text like this</i>	Represents variables (options for which you substitute a value) in commands or configuration statements.	Configure the machine's domain name: [edit] root@# set system domain-name <i>domain-name</i>
Plain text like this	Represents names of configuration statements, commands, files, and directories; IP addresses; configuration hierarchy levels; or labels on routing platform components.	<ul style="list-style-type: none"> To configure a stub area, include the stub statement at the [edit protocols ospf area area-id] hierarchy level. The console port is labeled CONSOLE.
< > (angle brackets)	Enclose optional keywords or variables.	stub <default-metric <i>metric</i> >;
(pipe symbol)	Indicates a choice between the mutually exclusive keywords or variables on either side of the symbol. The set of choices is often enclosed in parentheses for clarity.	broadcast multicast (<i>string1</i> <i>string2</i> <i>string3</i>)
# (pound sign)	Indicates a comment specified on the same line as the configuration statement to which it applies.	rsvp { # Required for dynamic MPLS only
[] (square brackets)	Enclose a variable for which you can substitute one or more values.	community name members [<i>community-ids</i>]
Indentation and braces ({ })	Identify a level in the configuration hierarchy.	[edit] routing-options { static { route default { nexthop <i>address</i> ; retain; } } }
;(semicolon)	Identifies a leaf statement at a configuration hierarchy level.	

J-Web GUI Conventions

Table 2: Text and Syntax Conventions (*continued*)

Convention	Description	Examples
Bold text like this	Represents J-Web graphical user interface (GUI) items you click or select.	<ul style="list-style-type: none"> In the Logical Interfaces box, select All Interfaces. To cancel the configuration, click Cancel.
> (bold right angle bracket)	Separates levels in a hierarchy of J-Web selections.	In the configuration editor hierarchy, select Protocols>Ospf .

Repair and Warranty



CAUTION: Many repairs may only be done by a certified service technician. You should only perform troubleshooting and simple repairs as authorized in your product documentation, or as directed by the online or telephone service and support team. Damage due to servicing that is not authorized by Dell is not covered by your warranty. Read and follow the safety instructions that came with the product.

Requesting Technical Support

For technical support, see <http://www.support.dell.com>.

PART 1

J-SRX240 Services Gateway Overview

- Introduction to the J-SRX240 Services Gateway on page 3
- J-SRX240 Services Gateway Hardware Components and Specifications on page 7
- J-SRX240 Services Gateway Mini-Physical Interface Modules on page 23
- J-SRX240 Services Gateway Power over Ethernet Support on page 25
- J-SRX240 Services Gateway with Integrated Convergence Services on page 29

CHAPTER 1

Introduction to the J-SRX240 Services Gateway

This chapter includes the following topics:

- J-SRX240 Services Gateway Description on page 3
- J-SRX240 Services Gateway Hardware Features on page 4

J-SRX240 Services Gateway Description

This topic includes the following sections:

- About the J-SRX240 Services Gateway on page 3
- J-SRX240 Services Gateway Models on page 3
- Accessing the J-SRX240 Services Gateway on page 4

About the J-SRX240 Services Gateway

The PowerConnect J-Series J-SRX240 Services Gateway offers complete functionality and flexibility for delivering secure, reliable data and voice services over IP, along with multiple interfaces that support WAN and LAN connectivity. Besides SIP/analog voice support, additional features include DSLAM, flexible data/voice T1/E1, and Power over Ethernet (PoE).

The services gateway provides Internet Protocol Security (IPsec), virtual private network (VPN), and firewall services for small-sized and medium-sized companies and enterprise branch and remote offices.

The J-SRX240 Services Gateway runs the JUNOS operating system.

J-SRX240 Services Gateway Models

The J-SRX240 Services Gateway is available in four models, which are listed in Table 3 on page 3.

Table 3: J-SRX240 Services Gateway Models

Product Name	Device Type	Model Number
J-SRX240 Services Gateway	Low Memory	J-SRX240B

Table 3: J-SRX240 Services Gateway Models (continued)

Product Name	Device Type	Model Number
J-SRX240 Services Gateway	High Memory	J-SRX240H
J-SRX240 Services Gateway with PoE	Power over Ethernet (PoE)	J-SRX240H-POE
J-SRX240 Services Gateway with Integrated Convergence Services	Voice	J-SRX240H-P-MGW

All J-SRX240 Services Gateways run the JUNOS operating system.

Accessing the J-SRX240 Services Gateway

You can use two user interfaces to monitor, configure, troubleshoot, and manage the J-SRX240 Services Gateway:

- **J-Web interface:** Web-based graphical interface that allows you to operate a services gateway without commands. The J-Web interface provides access to all JUNOS functionality and features.
- **JUNOS command-line interface (CLI):** JUNOS command shell that runs on top of a UNIX-based operating system kernel. The CLI is a straightforward command interface. On a single line, you type commands that are executed when you press the Enter key. The CLI provides command Help and command completion.

- Related Topics**
- J-SRX240 Services Gateway Hardware Features on page 4
 - J-SRX240 Services Gateway Specifications on page 7

J-SRX240 Services Gateway Hardware Features

Table 4 on page 4 lists the hardware features supported on the J-SRX240 Services Gateway.

Table 4: J-SRX240 Services Gateway Hardware Features

Features	J-SRX240 Services Gateway Low Memory	J-SRX240 Services Gateway High Memory	J-SRX240 Services Gateway PoE	J-SRX240 Services Gateway with Integrated Convergence Services
DDR memory	512 MB	1 GB	1 GB	1 GB
PoE support	No	No	Yes	Yes
Power supply rating	180 watts	180 watts	360 watts	360 watts
AC input voltage	100 to 240 VAC	100 to 240 VAC	100 to 240 VAC	100 to 240 VAC

Table 4: J-SRX240 Services Gateway Hardware Features (*continued*)

Features	J-SRX240 Services Gateway Low Memory	J-SRX240 Services Gateway High Memory	J-SRX240 Services Gateway PoE	J-SRX240 Services Gateway with Integrated Convergence Services
Gigabit Ethernet ports	16	16	16	16
Console port	1	1	1	1
Universal serial bus (USB) ports	2	2	2	2
Foreign Exchange Subscriber (FXS) and Foreign Exchange Office (FXO) interface	None	None	None	2 FXS ports and 2 FXO ports
Mini-PIM slots	4	4	4	4
LEDs	Status, Alarm, HA, Power, Mini-PIMs, and Port (TX/RX/Link and PoE) NOTE: The PoE LED is enabled only on the PoE variant of the J-SRX240 Services Gateway. For non-PoE gateways, the PoE LED remains off.	Status, Alarm, HA, Power, Mini-PIMs, and Port (TX/RX/Link and PoE) NOTE: The PoE LED is enabled only on the PoE variant of the J-SRX240 Services Gateway. For non-PoE gateways, the PoE LED remains off.	Status, Alarm, HA, Power, Mini-PIMs, and Port (TX/RX/Link and PoE)	Status, Alarm, HA, Power, Mini-PIMs, and Port (TX/RX/Link and PoE), and Voice Interface
Internal flash	1 GB	1 GB	1 GB	2 GB
Fans	6	6	6	6

For more details, see “J-SRX240 Services Gateway Specifications” on page 7.

For more details on J-SRX240 Services Gateway software features and licenses, see *JUNOS Software Administration Guide*.

- Related Topics**
- J-SRX240 Services Gateway Description on page 3
 - J-SRX240 Services Gateway Specifications on page 7

CHAPTER 2

J-SRX240 Services Gateway Hardware Components and Specifications

This chapter describes the hardware components and specifications of the J-SRX240 Services Gateway and includes the following topics:

- J-SRX240 Services Gateway Specifications on page 7
- J-SRX240 Services Gateway Front Panel and Back Panel Views on page 9
- J-SRX240 Services Gateway with Integrated Convergence Services Front Panel and Back Panel Views on page 11
- J-SRX240 Services Gateway Built-In Interfaces on page 13
- J-SRX240 Services Gateway LEDs on page 14
- J-SRX240 Services Gateway Boot Devices and Dual-Root Partitioning Scheme on page 19
- J-SRX240 Services Gateway Power Supply on page 20
- J-SRX240 Services Gateway Cooling System on page 20

J-SRX240 Services Gateway Specifications

Figure 1 on page 7 shows the J-SRX240 Services Gateway chassis.

Figure 1: J-SRX240 Services Gateway

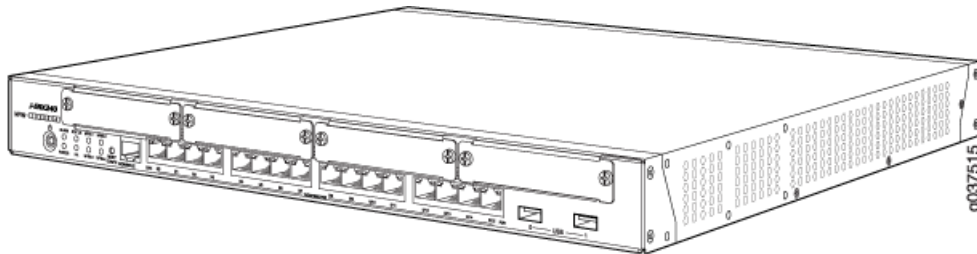

Table 5 on page 8 lists the J-SRX240 Services Gateway specifications.

Table 5: J-SRX240 Services Gateway Specifications

Specification	Value
Chassis height	1 Unit (U)
Chassis width	17.5 in. (44.5 cm)
Chassis depth	15 in. (38.1 cm)
Chassis weight	12.7 lb. (5.75 kg)
Power consumption	<ul style="list-style-type: none"> J-SRX240 Services Gateway Low Memory: 119 watts J-SRX240 Services Gateway High Memory: 128 watts J-SRX240 Services Gateway PoE: 317 watts J-SRX240 Services Gateway with Integrated Convergence Services: 350 watts
Altitude	No performance degradation to 10,000 ft (3048 m)
Relative humidity	5% to 90%, noncondensing
Temperature	<p>Normal operation ensured in temperature range of 32°F (0°C) to 104°F (40°C)</p> <p>Nonoperating storage temperature in shipping container: –40°F (–40°C) to 158°F (70°C)</p>
Seismic	Designed to meet Telcordia Technologies Zone 4 earthquake requirements
Maximum Thermal Output	<p>Note: These specifications are estimates and subject to change.</p> <ul style="list-style-type: none"> J-SRX240 Services Gateway Low Memory: 396 BTU/hour (116 watts) (AC power) J-SRX240 Services Gateway High Memory: 427 BTU/hour (125 watts) J-SRX240 Services Gateway PoE: 560 BTU/hour (164 watts) (AC power) J-SRX240 Services Gateway with Integrated Convergence Services: 683 BTU/hour (200 watts) (AC power)
Noise level	Less than 70 dB(A) as per EN ISO 7779

- Related Topics**
- J-SRX240 Services Gateway Description on page 3
 - J-SRX240 Services Gateway Hardware Features on page 4
 - J-SRX240 Services Gateway Front Panel and Back Panel Views on page 9
 - J-SRX240 Services Gateway Built-In Interfaces on page 13
 - J-SRX240 Services Gateway LEDs on page 14
 - J-SRX240 Services Gateway Boot Devices and Dual-Root Partitioning Scheme on page 19
 - J-SRX240 Services Gateway Power Supply on page 20
 - J-SRX240 Services Gateway Cooling System on page 20

J-SRX240 Services Gateway Front Panel and Back Panel Views

This topic contains views of the front panel and back panel of the J-SRX240 Services Gateway High Memory and Low Memory versions. This topic includes the following sections:

- J-SRX240 Services Gateway Front Panel (High Memory and Low Memory) on page 9
- J-SRX240 Services Gateway Back Panel (PoE, High Memory, and Low Memory) on page 11

J-SRX240 Services Gateway Front Panel (High Memory and Low Memory)

Figure 2 on page 9 shows the front panel of the J-SRX240 Services Gateway.

Figure 2: J-SRX240 Services Gateway Front Panel (High Memory and Low Memory)

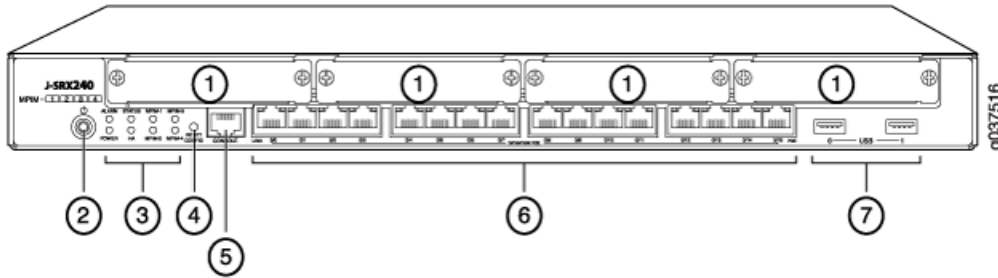

Table 6 on page 9 provides information about the front panel components of the services gateway.

Table 6: J-SRX240 Services Gateway Front Panel

Number	Component
1	Mini-PIM slots
2	Power button
3	LEDs: Status, Power, Mini-PIM, Alarm, HA
4	Reset Config button
5	Console port
6	Gigabit Ethernet ports
7	Universal serial bus (USB) ports

For more information on the front panel components, see the following topics:

- J-SRX240 Services Gateway Built-In Interfaces on page 13

- J-SRX240 Services Gateway LEDs on page 14
- J-SRX240 Services Gateway Boot Devices and Dual-Root Partitioning Scheme on page 19

J-SRX240 Services Gateway Back Panel (PoE, High Memory, and Low Memory)

Figure 3 on page 11 shows the back panel of the J-SRX240 Services Gateway.

Figure 3: J-SRX240 Services Gateway Back Panel (PoE, High Memory, and Low Memory)

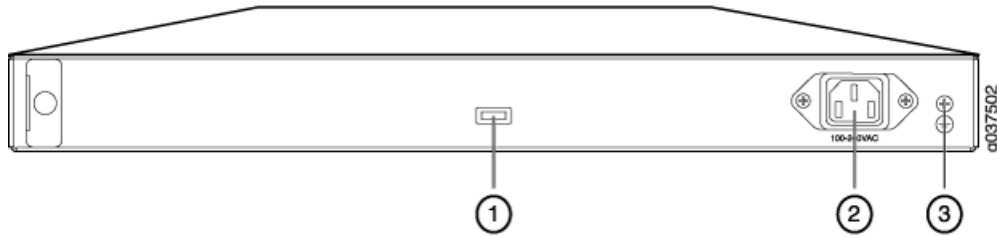

Table 7 on page 11 provides information about the back panel components of the services gateway.

Table 7: J-SRX240 Services Gateway Back Panel

Number	Component
1	Cable tie holder
2	Power supply point
3	Grounding point

- Related Topics**
- J-SRX240 Services Gateway Specifications on page 7
 - J-SRX240 Services Gateway Built-In Interfaces on page 13
 - J-SRX240 Services Gateway LEDs on page 14
 - J-SRX240 Services Gateway Boot Devices and Dual-Root Partitioning Scheme on page 19
 - J-SRX240 Services Gateway Power Supply on page 20
 - J-SRX240 Services Gateway Cooling System on page 20

J-SRX240 Services Gateway with Integrated Convergence Services Front Panel and Back Panel Views

This topic contains views of the front panel and back panel of the J-SRX240 Services Gateway with Integrated Convergence Services. This topic includes the following sections:

- J-SRX240 Services Gateway with Integrated Convergence Services Front Panel on page 12
- J-SRX240 Services Gateway with Integrated Convergence Services Back Panel on page 12

J-SRX240 Services Gateway with Integrated Convergence Services Front Panel

Figure 4 on page 12 illustrates the front panel of the J-SRX240 Services Gateway with Integrated Convergence Services.

Figure 4: J-SRX240 Services Gateway with Integrated Convergence Services Front Panel

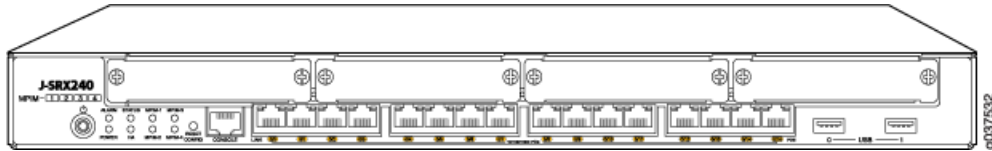

J-SRX240 Services Gateway with Integrated Convergence Services Back Panel

Figure 5 on page 12 illustrates the back panel of the J-SRX240 Services Gateway with Integrated Convergence Services.

Figure 5: J-SRX240 Services Gateway with Integrated Convergence Services Back Panel



Table 8 on page 12 lists the back panel components of the services gateway as they are labeled in Figure 5 on page 12.

Table 8: J-SRX240 Services Gateway with Integrated Convergence Services Back Panel

Number	Component
1	FXS port
2	FXO port
3	Power supply point
4	Grounding point

- Related Topics**
- J-SRX240 Services Gateway Specifications on page 7
 - J-SRX240 Services Gateway Built-In Interfaces on page 13
 - J-SRX240 Services Gateway LEDs on page 14
 - J-SRX240 Services Gateway Boot Devices and Dual-Root Partitioning Scheme on page 19
 - J-SRX240 Services Gateway Cooling System on page 20
 - J-SRX240 Services Gateway Power Supply on page 20

J-SRX240 Services Gateway Built-In Interfaces

Table 9 on page 13 summarizes the interface ports supported on the J-SRX240 Services Gateway.

Table 9: J-SRX240 Services Gateway Built-In Interfaces

Interface Type	Description	Usage
Gigabit Ethernet	<ul style="list-style-type: none"> 16 ports built into the chassis front panel Labeled as port ge-0/0/0 to ge-0/0/15 Provide link speeds of 10/100/1000 Mbps Operate in full-duplex and half-duplex modes <p>NOTE: On the PoE and Voice models of the J-SRX240 Services Gateway, all 16 Gigabit Ethernet ports support PoE.</p>	Function as front-end network ports and provide LAN and WAN connectivity to hubs, switches, local servers, and workstations.
Universal Serial Bus (USB)	<ul style="list-style-type: none"> Two ports built into the chassis front panel Labeled usb 0 and usb 1 Function in the following modes: <ul style="list-style-type: none"> Full speed High speed Compliant with USB revision 2.0 	<ul style="list-style-type: none"> Support a USB storage device that functions as a secondary boot device in case of internal flash failure on startup. <p>NOTE: To use USB to boot your services gateway, you must install and configure the USB storage device on the USB port to use it as a secondary boot device. Additionally, the USB device must have JUNOS installed.</p> <ul style="list-style-type: none"> Provide the USB interfaces that are used to communicate with many types of USB storage devices compatible with JUNOS Software. <p>Contact a customer service representative for more information.</p>
Console	<ul style="list-style-type: none"> One port built into the chassis front panel Uses an RJ-45 serial cable connector Supports the RS-232 (EIA-232) standard 	<ul style="list-style-type: none"> Functions as a management port to log into a device directly. Provides the interface to configure the device using the CLI.
Foreign Exchange Subscriber (FXS) interface	<ul style="list-style-type: none"> Two ports built into the chassis back panel Use an RJ-11 connector 	<ul style="list-style-type: none"> Provide an interface to connect analog phones, fax machines, or similar devices. Supply battery power, ringing voltage, dial tone, and so on to the station. <p>NOTE: There is a hardware relay between the built-in FXO1 interface and the FXS2 interface. The relay automatically connects the FXS2 port and the FXO1 port in the event of a power failure.</p>

Table 9: J-SRX240 Services Gateway Built-In Interfaces (*continued*)

Interface Type	Description	Usage
Foreign Exchange Office (FXO) interface	<ul style="list-style-type: none"> Two ports built into the chassis back panel Use an RJ-11 connector 	Provide direct connection to the telephone exchange or Public Switched Telephone Networks (PSTN) central office.
Mini-PIM slots	<ul style="list-style-type: none"> Four slots built into the chassis front panel Mini-PIMs can be plugged directly into the slots 	Provide LAN and WAN functionality along with connectivity to various media types. For more information about Mini-PIMs, see the <i>J-SRX Series Services Gateways for the Branch Physical Interface Modules Hardware Guide</i> .



NOTE: We recommend the use of transceivers compatible with JUNOS Software. We cannot guarantee that the interface module will operate correctly if transceivers are not compatible with JUNOS Software. Please contact Dell for the correct transceiver part number for your device.

Related Topics

- J-SRX240 Services Gateway Specifications on page 7
- J-SRX240 Services Gateway Front Panel and Back Panel Views on page 9
- J-SRX240 Services Gateway LEDs on page 14
- J-SRX240 Services Gateway Boot Devices and Dual-Root Partitioning Scheme on page 19
- J-SRX240 Services Gateway Power Supply on page 20
- J-SRX240 Services Gateway Cooling System on page 20

J-SRX240 Services Gateway LEDs

This topic includes the following sections:

- Front Panel LEDs on page 14
- Ethernet Port LEDs on page 16
- Voice Interface Port LED on page 17

Front Panel LEDs

Figure 6 on page 15 shows the J-SRX240 Services Gateway front panel LEDs.

Figure 6: J-SRX240 Services Gateway Front Panel LEDs

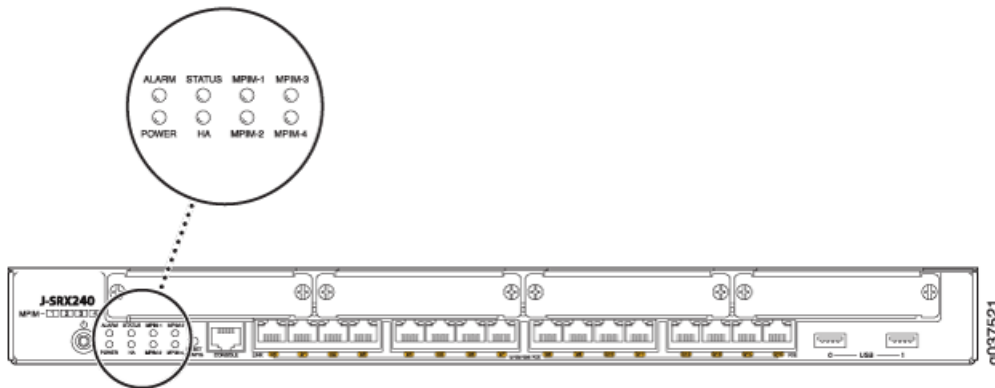

Table 10 on page 15 lists the LED indicators on the J-SRX240 Services Gateway front panel.

Table 10: J-SRX240 Services Gateway Front Panel Components

Component	Description	Usage
Status LED	<p>The Status LED has the following indicator colors:</p> <ul style="list-style-type: none"> Green and steadily on indicates that the device is functioning normally. Amber and steadily on indicates that the device is starting up. Red and steadily on indicates that the device has failed. 	The Status LED can be used to determine whether the device is starting up, is functioning normally, or has failed.
Alarm LED	<p>The Alarm LED has the following indicator colors:</p> <ul style="list-style-type: none"> Red and steadily on indicates a major alarm. Amber and steadily on indicates a minor alarm. Off indicates that the device is starting up. <p>NOTE: When the system is up and running, if the Alarm LED is off, it indicates that no alarms are present on the device.</p>	The Alarm LED can be used to gather information on major or minor alarms or to determine if the device is functioning normally.
Power LED	<p>The Power LED has the following indicator colors:</p> <ul style="list-style-type: none"> Green and steadily on indicates that the device is functioning normally. Amber and steadily on indicates that the Power button has been pressed and quickly released. The device is gracefully shutting down. Off indicates that the device is not receiving power. 	The Power LED can be used to determine if the device is receiving power.

Table 10: J-SRX240 Services Gateway Front Panel Components (*continued*)

Component	Description	Usage
HA LED	<p>The HA LED has the following indicator colors:</p> <ul style="list-style-type: none"> Green and steadily on indicates that all HA links are available. Red and steadily on indicates that the HA links are not working as expected. Amber and steadily on indicates that some HA links are not working as expected. Off indicates that HA is not enabled. 	The HA LED can be used to determine if the chassis clustering is enabled on the device.
Mini-PIM LED	<p>Each Mini-Physical Interface Module (Mini-PIM) LED has the following indicator colors:</p> <ul style="list-style-type: none"> Green and steadily on indicates that the Mini-PIM is functioning normally. Off indicates that the Mini-PIM is not present or not detected by the device. 	The Mini-PIM LED can be used to determine if the Mini-PIM is present and detected by the device.

Ethernet Port LEDs

On the J-SRX240 Services Gateway, each Gigabit Ethernet port has the two LEDs as shown in Figure 7 on page 16.

Figure 7: J-SRX240 Services Gateway Port LEDs

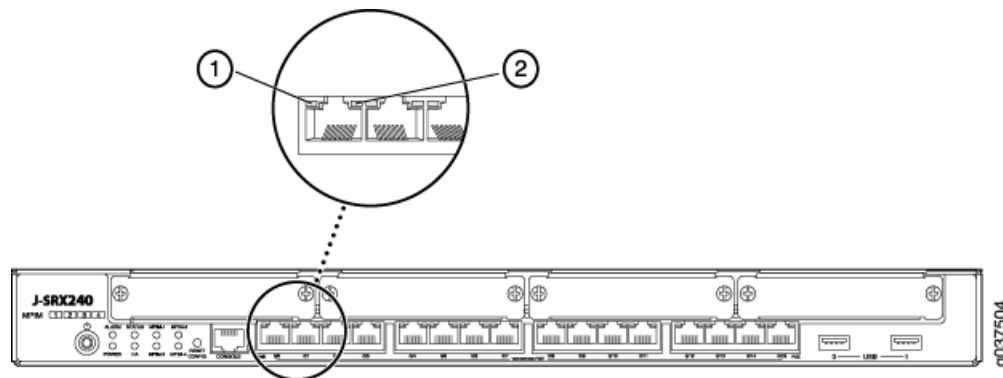

Table 11: J-SRX240 Services Gateway Port LEDs

Number	LED
1	PoE (Power over Ethernet) LED
2	TX/RX/Link LED



NOTE: The PoE LED is enabled only on the PoE variant of the J-SRX240 Services Gateway. For non-PoE services gateways, the PoE LED remains off.

Table 12 on page 17 describes the Ethernet port LEDs.

Table 12: J-SRX240 Services Gateway Ethernet Port LEDs

Function	Color	State	Description
TX/RX/Link	Green	Blinking	Link is active. Data communication is taking place.
		Steady	Link is active. No data communication is taking place.
	Unlit	Off	Link is inactive.
PoE Status	Green	Steady	PoE is activated and the connected power device is receiving power.
	Yellow	Steady	PoE is activated, but the connected power device is not receiving power (fault or not enough power).
	Unlit	Off	PoE is disabled or no device is drawing power.

Voice Interface Port LED

On the J-SRX240 Services Gateway, each Voice Interface (FXO and FXS) port has a single LED indicating the status of the port.

Figure 8 on page 17 shows the J-SRX240 Services Gateway Voice Interface port LEDs.

Figure 8: J-SRX240 Services Gateway Voice Interface port LEDs

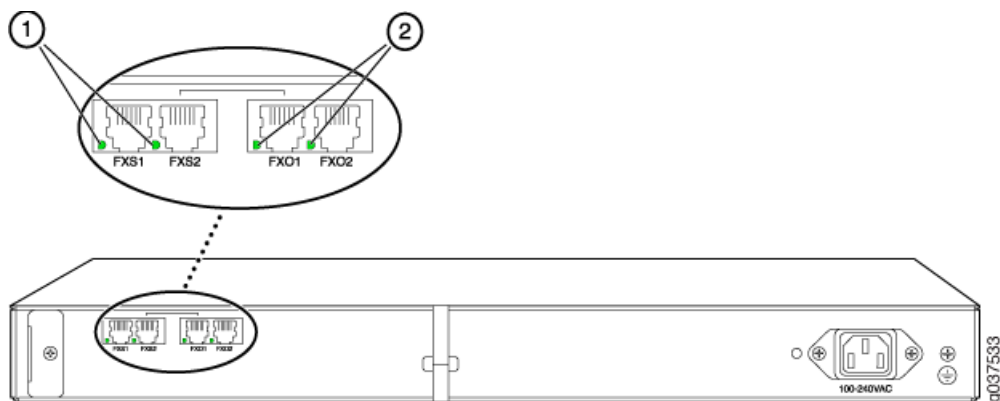

Table 13: J-SRX240 Services Gateway Voice Interface Port LEDs

Number	LED
1	FXS1, FXS2 LEDs
2	FXO1, FXO2 LEDs

Table 14 on page 18 describes the Voice Interface port LEDs.

Table 14: J-SRX240 Services Gateway Voice Interface Port LEDs

Function	Color	State	Description
Voice Interface LEDs	Off	Unlit	Port is inactive.
	Green	Steady	Port is connected and active.
	Amber	On	Port is active and not ready for data communication.
	Green	Blinking	Port is active and data communication is taking place.
	Red	Blinking	Port is initializing. NOTE: The Voice Interface port LED glows red (blinking) while initializing. If there is an error, the LED remains red; otherwise, changes to green.
	Red	Steady	Port has detected a hardware initialization failure.

- Related Topics**
- J-SRX240 Services Gateway Specifications on page 7
 - J-SRX240 Services Gateway Front Panel and Back Panel Views on page 9
 - J-SRX240 Services Gateway Built-In Interfaces on page 13
 - J-SRX240 Services Gateway Boot Devices and Dual-Root Partitioning Scheme on page 19
 - J-SRX240 Services Gateway Power Supply on page 20
 - J-SRX240 Services Gateway Cooling System on page 20

J-SRX240 Services Gateway Boot Devices and Dual-Root Partitioning Scheme

This topic includes the following sections:

- [Boot Devices on page 19](#)
- [Dual-Root Partitioning Scheme on page 19](#)

Boot Devices

The J-SRX240 Services Gateway can boot from the following storage media (in the order of priority):

- Internal NAND flash (default; always present)
- USB storage key (alternate)

Dual-Root Partitioning Scheme

Dual-root partitions allow the J-SRX240 Services Gateways to remain functional if there is file system corruption and facilitate easy recovery of the corrupted file system.

The dual-root partitioning scheme keeps the primary and backup JUNOS Software images in two independently bootable root partitions. If the primary root partition becomes corrupted, the system will be able to boot from the backup JUNOS Software image located in the other root partition and remain fully functional.

When the J-SRX240 Services Gateway powers up, it tries to boot the JUNOS Software from the default storage media. If the device fails to boot from the default storage media, it tries to boot from the alternate storage media. With the dual-root partitioning scheme, the J-SRX240 Services Gateway first tries to boot the JUNOS Software from the primary root partition and then from the backup root partition on the default storage media. If both primary and backup root partitions of a media fail to boot, then the device tries to boot from the next available type of storage media. The J-SRX240 Services Gateway remains fully functional even if it boots the JUNOS Software from the backup root partition of storage media.

- Related Topics**
- [J-SRX240 Services Gateway Specifications on page 7](#)
 - [J-SRX240 Services Gateway Front Panel and Back Panel Views on page 9](#)
 - [J-SRX240 Services Gateway Built-In Interfaces on page 13](#)
 - [J-SRX240 Services Gateway LEDs on page 14](#)
 - [J-SRX240 Services Gateway Power Supply on page 20](#)
 - [J-SRX240 Services Gateway Cooling System on page 20](#)

J-SRX240 Services Gateway Power Supply

The J-SRX240 Services Gateway uses an internal AC power supply. The power supply distributes the different output voltages to the device components according to their voltage requirements. The power supply is fixed in the chassis and is not field-replaceable.

The AC power supply has a single AC appliance inlet that requires a dedicated AC power feed.

- Related Topics**
- J-SRX240 Services Gateway Specifications on page 7
 - J-SRX240 Services Gateway Front Panel and Back Panel Views on page 9
 - J-SRX240 Services Gateway Built-In Interfaces on page 13
 - J-SRX240 Services Gateway LEDs on page 14
 - J-SRX240 Services Gateway Boot Devices and Dual-Root Partitioning Scheme on page 19
 - J-SRX240 Services Gateway Cooling System on page 20

J-SRX240 Services Gateway Cooling System

The J-SRX240 Services Gateway has six cooling fans.

The cooling system works from side-to-side in the services gateway chassis. The fans draw air through vents along the left side of the chassis and exhaust the air through vents on the right side of the chassis as shown in Figure 9 on page 21.

The airflow produced by these fans keeps device components within the acceptable temperature range.

Figure 9: Airflow Through the J-SRX240 Services Gateway Chassis

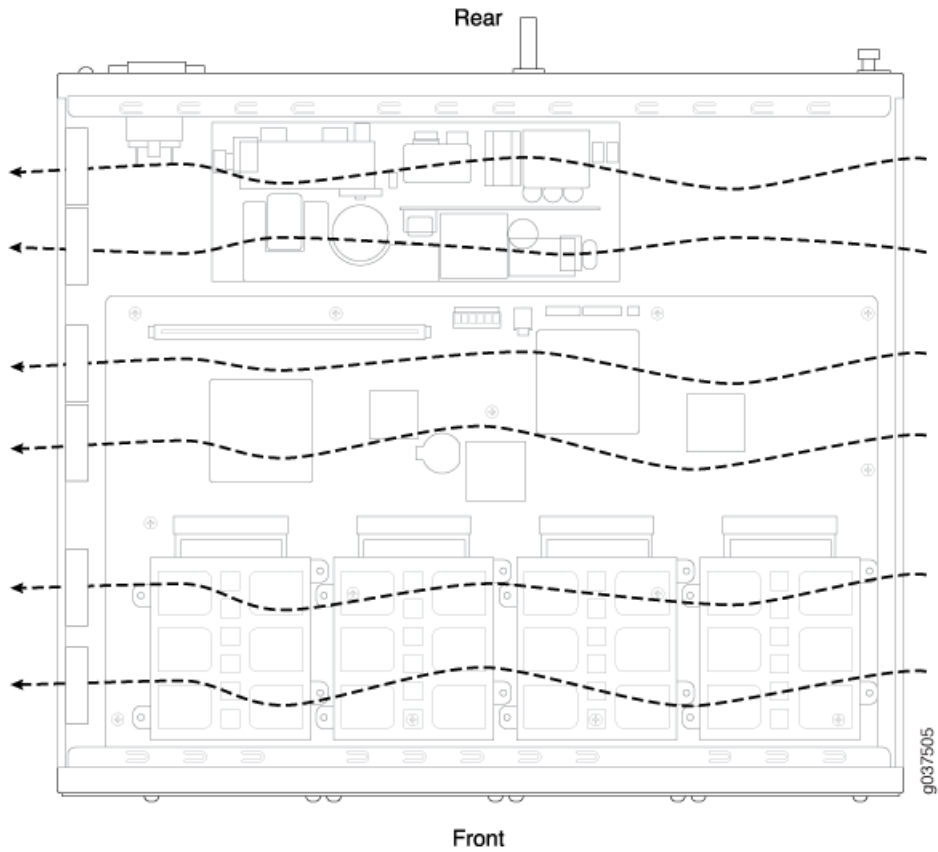

- Related Topics**
- J-SRX240 Services Gateway Specifications on page 7
 - J-SRX240 Services Gateway Front Panel and Back Panel Views on page 9
 - J-SRX240 Services Gateway Built-In Interfaces on page 13
 - J-SRX240 Services Gateway LEDs on page 14
 - J-SRX240 Services Gateway Boot Devices and Dual-Root Partitioning Scheme on page 19
 - J-SRX240 Services Gateway Power Supply on page 20

CHAPTER 3

J-SRX240 Services Gateway Mini-Physical Interface Modules

This chapter includes the following topic:

- Mini-Physical Interface Modules on the J-SRX240 Services Gateway on page 23

Mini-Physical Interface Modules on the J-SRX240 Services Gateway

The J-SRX240 Services Gateway supports Mini-Physical Interface Modules (Mini-PIMs).

A Mini-PIM is a network interface card (NIC) that is installed on the J-SRX240 Services Gateway to provide physical connections to a LAN or a WAN. The Mini-PIM receives incoming packets from the network and transmits outgoing packets to the network.

The Mini-PIMs supported on the J-SRX240 Services Gateway are field-replaceable, meaning that they are removable and insertable into the device. You can install a Mini-PIM into the Mini-PIM slots available on the front panel of the services gateway chassis.



CAUTION: The Mini-PIMs available on the J-SRX240 Services Gateway are not hot-swappable. You need to power off the device before removing or installing Mini-PIMs.

For more information about supported Mini-PIMs, including how to install and configure Mini-PIMs, refer to the *J-SRX Series Services Gateways for the Branch Physical Interface Modules Hardware Guide*.

Related Topics

- J-SRX240 Services Gateway Specifications on page 7
- J-SRX240 Services Gateway Front Panel and Back Panel Views on page 9
- J-SRX240 Services Gateway LEDs on page 14
- J-SRX240 Services Gateway Built-In Interfaces on page 13
- J-SRX240 Services Gateway Cooling System on page 20

CHAPTER 4

J-SRX240 Services Gateway Power over Ethernet Support

This chapter includes the following topics:

- J-SRX240 Services Gateway Power over Ethernet Overview on page 25
- Configuring PoE Functionality on the J-SRX240 Services Gateway on page 26

J-SRX240 Services Gateway Power over Ethernet Overview

- Introduction on page 25
- PoE Classes and Power Ratings on page 26

Introduction

Power over Ethernet (PoE) provides the capability for both data and electric power to pass over a copper Ethernet LAN cable.

The J-SRX240 Services Gateway supports PoE on all Gigabit Ethernet ports. The PoE ports transfer electrical power, along with data, to remote devices over standard twisted-pair cable in an Ethernet network. PoE ports allow you to plug in devices that require both network connectivity and electric power, such as wireless LAN access points, and VoIP telephones.

You can configure the services gateway to act as power sourcing equipment for devices connected on the designated ports.

Table 15 on page 25 lists the J-SRX240 Services Gateway PoE specifications.

Table 15: J-SRX240 Services Gateway PoE Specifications

Power Management Schemes	Values
Supported standards	<ul style="list-style-type: none">• IEEE 802.3 AF• IEEE 802.3 AT (PoE+)• Legacy (pre-standards)
Supported ports	PoE is supported on all 16 Gigabit Ethernet ports (ge-0/0/0 to ge-0/0/15)
Total PoE power sourcing capacity	150 watts

Table 15: J-SRX240 Services Gateway PoE Specifications (*continued*)

Power Management Schemes	Values
Per port power limit	30 watts NOTE: Default value is 15.4 watts
Power management modes	<ul style="list-style-type: none"> • Static: Power allocated for each interface can be configured. • Class: Power allocated for interfaces is decided based on the class of powered device connected.

PoE Classes and Power Ratings

A powered device is classified based on the maximum power that it draws across all input voltages and operational modes. When class-based power management mode is configured on the services gateway, power is allocated taking into account the maximum power ratings defined for the different classes of devices.

Table 16 on page 26 lists the classes and their power ratings as specified by the IEEE 802.3 AF standard.

Table 16: PoE Classes and Power Ratings

Class	Minimum Power Level Output from PoE Port
0	15.4 watts
1	4.0 watts
2	7.0 watts
3	15.4 watts
4	30.0 watts

- Related Topics**
- J-SRX240 Services Gateway Description on page 3
 - J-SRX240 Services Gateway Specifications on page 7
 - J-SRX240 Services Gateway Front Panel and Back Panel Views on page 9
 - J-SRX240 Services Gateway Built-In Interfaces on page 13
 - J-SRX240 Services Gateway LEDs on page 14
 - Mini-Physical Interface Modules on the J-SRX240 Services Gateway on page 23

Configuring PoE Functionality on the J-SRX240 Services Gateway

To enable the PoE feature support on your J-SRX240 Services Gateway, you must configure the services gateway.

You can configure PoE using the CLI configuration editor.

For more details on configuring PoE, see the *JUNOS Software Interfaces and Routing Configuration Guide*.

- Related Topics**
- J-SRX240 Services Gateway Description on page 3
 - J-SRX240 Services Gateway Specifications on page 7
 - J-SRX240 Services Gateway Front Panel and Back Panel Views on page 9
 - J-SRX240 Services Gateway Built-In Interfaces on page 13
 - J-SRX240 Services Gateway LEDs on page 14
 - Mini-Physical Interface Modules on the J-SRX240 Services Gateway on page 23

CHAPTER 5

J-SRX240 Services Gateway with Integrated Convergence Services

This chapter includes the following topics:

- Introducing the J-SRX240 Services Gateway with Integrated Convergence Services on page 29
- Understanding the Functions of the J-SRX240 Services Gateway with Integrated Convergence Services on page 31
- J-SRX240 Services Gateway with Integrated Convergence Services Interoperability on page 31
- Configuring the J-SRX240 Services Gateway with Integrated Convergence Services on page 32

Introducing the J-SRX240 Services Gateway with Integrated Convergence Services

This topic includes following sections:

- Features and Functions on page 29
- Basic Functions on page 30
- Common Deployment Scenarios on page 30

Features and Functions

The availability of hardware and software for voice and data transmission on the same device is called *integrated convergence services*.

J-SRX240 Services Gateway with Integrated Convergence Services implements a media gateway and a survivable call server. The J-SRX240 Services Gateway with Integrated Convergence Services integrates voice and data capabilities and provides a generic SIP-based voice over IP (VoIP) Media Gateway (SVMG) capability for local public switched telephone network (PSTN) and legacy analog/fax/phone connectivity. This feature enables standard phones to be used for voice calls over the Internet.

The J-SRX240 Services Gateway with Integrated Convergence Services also offers the following additional features:

- Voice mail answering and retrieval via PSTN digit mapping
- Digit manipulation for remapping digits
- Caller ID support for detection and transmission of caller information (for USA standards)
- Call waiting for SIP phones in which the user is alerted about a pending, incoming call
- Call hold and resume in which SIP calls may be placed on hold and resumed by the SIP phone user
- Local auto attendant with a standard workflow, allowing the caller to enter an extension number to reach the call destination

Basic Functions

The J-SRX240 Services Gateway with Integrated Convergence Services performs the following basic functions:

- Bridges the VoIP network to the PSTN so that calls can be made from remote SIP and PSTN phones and routed to local analog telephones, fax machines, and local SIP phones behind the media gateway
- Assumes the call routing role as a survivable call server for local SIP or analog phones, in the event of loss of WAN connection
- Supports emergency calling (E911) by providing the mechanism for detecting emergency calls from local VoIP phones and passes these calls to the PSTN when detected
- Provides lifeline support in the event of power loss by connecting a port that has an analog phone to a port that is connected to the PSTN
- Provides power failover support for one analog phone and PSTN FXO port

Common Deployment Scenarios

The J-SRX240 Services Gateway with Integrated Convergence Services is deployed in the following environments:

- Enterprises that deploy VoIP in their headquarters and want to enable VoIP functionality for their branch offices
- Services providers (SPs) who provide VoIP services to their business customers
- Branch sites currently using a local key system/PBX that want to utilize SIP trunking services
- Branch sites that use a local IP-PBX connected to the users through analog or digital lines

- Related Topics**
- [Configuring the J-SRX240 Services Gateway with Integrated Convergence Services on page 32](#)

- Understanding the Functions of the J-SRX240 Services Gateway with Integrated Convergence Services on page 31

Understanding the Functions of the J-SRX240 Services Gateway with Integrated Convergence Services

The J-SRX240 Services Gateway with Integrated Convergence Services functions as follows:

- Analog telephones and fax machines are directly connected to the J-SRX240 Services Gateway with Integrated Convergence Services through Foreign Exchange Station (FXS) interfaces.
- The telephone exchange or PSTN central office (CO) is directly connected to the J-SRX240 Services Gateway with Integrated Convergence Services through Foreign Exchange Office (FXO) interfaces.
- The media gateway converts analog signals from FXS and FXO ports and digital TDM signals from T1/E1 ports to VoIP packets and sends them to the network after processing through JUNOS Software secure routing and firewall flows. Similarly, the media gateway receives forwarded VoIP packets from the network, converts them into analog signals or digital TDM signals, and sends them across the appropriate interface.
- The media gateway also provides power failover support in the event of power loss by providing a hardware relay between the built-in FXS2 port and FXO1 port, which automatically connects the two ports when the media gateway loses power.



NOTE: The 2-Port FXS/2-Port FXO Mini-PIM and the 4-Port FXO Mini-PIM do not support failover relay between any of the FXS and FXO ports.

- Telephony interface expansion available through Mini-PIM interface card options includes a 2-Port FXS/2-Port FXO Mini-PIM, a 4-Port FXO Mini-PIM, and an IP Flex T1/E1 Mini-PIM with initial support for T1-CAS (loopstart only).



NOTE: For more information on Mini-PIMs, see the *J-SRX Series Services Gateways for the Branch Physical Interface Modules Hardware Guide*.

Related Topics

- Introducing the J-SRX240 Services Gateway with Integrated Convergence Services on page 29
- Configuring the J-SRX240 Services Gateway with Integrated Convergence Services on page 32

J-SRX240 Services Gateway with Integrated Convergence Services Interoperability

The J-SRX240 Services Gateway with Integrated Convergence Services aligns with open convergence architecture and supports different brands of call servers and SIP phones.

Table 17 on page 32 summarizes the SIP phones, softphones, and analog devices supported by the J-SRX240 Services Gateway with Integrated Convergence Services.

Table 17: J-SRX240 Services Gateway Integrated Convergence Services Interoperability

Phone Types	Devices
SIP phones	<ul style="list-style-type: none"> • Avaya 4600 and 9600 series • Polycom 300 and 500 series • Snom 300 series • Microsoft OCS-compatible phones • Cisco Unified SIP phones 7960 and 7961
Softphones	<ul style="list-style-type: none"> • SNOM 360 • Microsoft OCS client • X-Lite EyeBeam Mini-SIP • Avaya one-x
Analog devices	Any analog device connected through FXO, including phones, fax machines, PBX or key systems, voicemail or answering machine, and analog paging systems
SIP call servers	<ul style="list-style-type: none"> • Avaya CM 5.2 with SES • Avaya ASM (Aura 1.x) • Microsoft OCS R1 and R2 • Asterisk 1.6.x (Open Source)

- Related Topics**
- [Configuring the J-SRX240 Services Gateway with Integrated Convergence Services on page 32](#)
 - [Understanding the Functions of the J-SRX240 Services Gateway with Integrated Convergence Services on page 31](#)

[Configuring the J-SRX240 Services Gateway with Integrated Convergence Services](#)

To enable voice support on your J-SRX240 Services Gateway with Integrated Convergence Services, you must configure the services gateway.

You can configure the voice functionality using:

- CLI configuration editor
- J-Web configuration editor

For more details on configuring voice support, see the *Integrated Convergence Services Configuration and Administration Guide for J-SRX Series Services Gateways*.

- Related Topics**
- [Introducing the J-SRX240 Services Gateway with Integrated Convergence Services on page 29](#)

- Understanding the Functions of the J-SRX240 Services Gateway with Integrated Convergence Services on page 31

PART 2

Setting Up the J-SRX240 Services Gateway

- Preparing the Site for the J-SRX240 Services Gateway Installation on page 37
- Installation Overview for the J-SRX240 Services Gateway on page 43
- Required Tools and Parts for Installing and Maintaining the J-SRX240 Services Gateway on page 45
- Unpacking the J-SRX240 Services Gateway on page 47
- Installing the J-SRX240 Services Gateway on page 51
- Connecting, Grounding, and Powering On the J-SRX240 Services Gateway on page 55
- J-SRX240 Services Gateway Autoinstallation on page 61
- Connecting the J-SRX240 Services Gateway to Management Devices on page 63
- Performing Initial Software Configuration on the J-SRX240 Services Gateway on page 71

CHAPTER 6

Preparing the Site for the J-SRX240 Services Gateway Installation

This chapter includes the following topics:

- Site Preparation Checklist for the J-SRX240 Services Gateway on page 37
- General Site Guidelines for Installing the J-SRX240 Services Gateway on page 38
- J-SRX240 Services Gateway Rack Requirements on page 39
- Clearance Requirements for Airflow and Hardware Maintenance on the J-SRX240 Services Gateway on page 40
- J-SRX240 Services Gateway Electrical and Power Requirements on page 41
- J-SRX240 Services Gateway Network Cable Requirements and Specifications on page 41

Site Preparation Checklist for the J-SRX240 Services Gateway

The checklist in Table 18 on page 37 summarizes the tasks you need to perform when preparing a site for installing the J-SRX240 Services Gateway.

Table 18: Site Preparation Checklist for Services Gateway Installation

Item or Task	Additional Information	Date and Notes
Environment		
Verify that environmental factors such as temperature and humidity do not exceed device tolerances.	"J-SRX240 Services Gateway Specifications" on page 7	
Power		
Measure distance between external power sources and device installation site.	"J-SRX240 Services Gateway Electrical and Power Requirements" on page 41	
Locate sites for connection of system grounding.	"J-SRX240 Services Gateway Grounding Specifications" on page 125	
Calculate the power consumption and requirements.	"J-SRX240 Services Gateway Power Specifications and Requirements" on page 124	

Table 18: Site Preparation Checklist for Services Gateway Installation (*continued*)

Item or Task	Additional Information	Date and Notes
Rack Installation		
<ul style="list-style-type: none"> Verify that your rack meets the minimum requirements. Plan the rack location, including required space clearances. Secure the rack to the floor and the building structure. 	<p>“J-SRX240 Services Gateway Rack Requirements” on page 39</p>	
Cables		
<ul style="list-style-type: none"> Acquire cables and connectors. Review the maximum distance allowed for each cable. Choose the length of cable based on the distance between the hardware components being connected. Plan the cable routing and management. 	<p>“Interface Cable and Wire Specifications for the J-SRX240 Services Gateway” on page 127</p>	
Related Topics		

- J-SRX240 Services Gateway Specifications on page 7
- J-SRX240 Services Gateway Site Electrical Wiring Guidelines on page 123
- J-SRX240 Services Gateway Rack Requirements on page 39
- Clearance Requirements for Airflow and Hardware Maintenance of the J-SRX240 Services Gateway on page 40
- Interface Cable and Wire Specifications for the J-SRX240 Services Gateway on page 127
- General Site Guidelines for Installing the J-SRX240 Services Gateway on page 38

General Site Guidelines for Installing the J-SRX240 Services Gateway

The following precautions help you plan an acceptable operating environment for your J-SRX240 Services Gateway and avoid environmentally caused equipment failures:

- For the cooling system to function properly, the airflow around the chassis must be unrestricted. Allow sufficient clearance between the front and back of the chassis and adjacent equipment. Ensure that there is adequate circulation in the installation location.
- Follow the ESD procedures to avoid damaging equipment. Static discharge can cause components to fail completely or intermittently over time.

- Ensure that the blank Mini-PIM panel is installed in the empty slot to prevent any interruption or reduction in the flow of air across internal components.



NOTE: Install the device only in restricted areas, such as dedicated equipment rooms and equipment closets, in accordance with Articles 110–16, 110–17, and 110–18 of the National Electrical Code, ANSI/NFPA 70.

Related Topics

- J-SRX240 Services Gateway Specifications on page 7
- J-SRX240 Services Gateway Site Electrical Wiring Guidelines on page 123
- J-SRX240 Services Gateway Rack Requirements on page 39
- Clearance Requirements for Airflow and Hardware Maintenance on the J-SRX240 Services Gateway on page 40
- Interface Cable and Wire Specifications for the J-SRX240 Services Gateway on page 127

J-SRX240 Services Gateway Rack Requirements

The services gateway can be installed in a rack. Many types of racks are acceptable, including front-mount racks and four-post (telco) racks.



NOTE: The services gateway does not support center-mount racks.

Table 19 on page 39 provides the details on rack size, clearance, and airflow requirements.

Table 19: Rack Requirements for the Services Gateway

Rack Requirements	Specifications
Rack Size	A 19 in. (48.3 cm) rack as defined in <i>Cabinets, Racks, Panels, and Associated Equipment</i> (document number EIA-310-D) published by the Electronics Industry Association (http://www.eia.org).
Rack Requirements	<ul style="list-style-type: none"> • The outer edges of the mounting brackets extend the width of either chassis to 19 in. (48.3 cm). • The front of the chassis extends approximately 0.5 in. (1.27 cm) beyond the mounting ears. • Maximum permissible ambient temperature when two devices are placed side by side in a 19 in. rack is 40° C. • In a rack, two devices should be placed in alternate slots and not adjacent. <p>NOTE: If you use a front-mount rack, we recommend you support the back of the device with a shelf or other structure.</p>
Spacing of Mounting Bracket and Flange Holes	<ul style="list-style-type: none"> • The holes within each rack set are spaced at 1 U [1.75 in. (4.5 cm)]. The device can be mounted in any rack that provides holes or hole patterns spaced at 1-U [1.75 in. (4.5 cm)] increments. • The mounting brackets and front-mount flanges used to attach the chassis to a rack are designed to fasten to holes spaced at rack distances of 1 U (1.75 in.). • The mounting holes in the mounting brackets provided with the device are spaced 1.25 in. (3.2 cm) apart (top and bottom mounting hole).

Table 19: Rack Requirements for the Services Gateway (*continued*)

Rack Requirements	Specifications
Connecting to the Building Structure	Always secure the rack in which you are installing the services gateway to the structure of the building. If your geographical area is subject to earthquakes, bolt the rack to the floor. For maximum stability, also secure the rack to ceiling brackets.

- Related Topics**
- General Site Guidelines for Installing the J-SRX240 Services Gateway on page 38
 - Clearance Requirements for Airflow and Hardware Maintenance of the J-SRX240 Services Gateway on page 40
 - J-SRX240 Services Gateway Network Cable Requirements and Specifications on page 41
 - J-SRX240 Services Gateway Electrical and Power Requirements on page 41

Clearance Requirements for Airflow and Hardware Maintenance on the J-SRX240 Services Gateway

When planning the installation site for the J-SRX240 Services Gateway, you need to allow sufficient clearance around the rack.

When planning the installation site for the services gateway, consider the following:

- For the cooling system to function properly, the airflow around the chassis must be unrestricted.
- For service personnel to service the device, there must be adequate space at the front and back of the device. Allow at least 24 in. (61 cm) both in front of and behind the device.
- If you are mounting the device in a rack with other equipment, or if you are placing it on the desktop near other equipment, ensure that the exhaust from other equipment does not blow into the intake vents of the chassis.

Table 20 on page 40 provides information on the clearance requirements for maintaining the optimum airflow and the distances for facilitating easy maintenance of the device.

Table 20: Clearance Requirements for the Services Gateway

Location	Recommended Clearance	Requirement for Clearance
Front of the chassis	2.5 in. (6.35 cm)	Space for service personnel to remove and install hardware components NOTE: More space is required for installing and removing Mini-PIMs.
Rear of the chassis	2.5 in. (6.35 cm)	Space for service personnel to remove and install hardware components
Between front-mounting flange and rack or cabinet edge	2.5 in. (6.35 cm)	Space for cable management and organization

Table 20: Clearance Requirements for the Services Gateway (*continued*)

Location	Recommended Clearance	Requirement for Clearance
Between side of the chassis and any non-heat-producing surface such as a wall or cabinet side	2.5 in. (6.35 cm)	Space for the cooling system to function properly and to maintain unrestricted airflow around the chassis
Between side of the chassis and devices that have fans or blowers	2.5 in. (6.35 cm)	Space for the cooling system to function properly and to maintain unrestricted airflow around the chassis

- Related Topics**
- General Site Guidelines for Installing the J-SRX240 Services Gateway on page 38
 - J-SRX240 Services Gateway Rack Requirements on page 39
 - J-SRX240 Services Gateway Network Cable Requirements and Specifications on page 41
 - J-SRX240 Services Gateway Electrical and Power Requirements on page 41

J-SRX240 Services Gateway Electrical and Power Requirements

There are factors you must consider while planning the electrical wiring and power availability at your site. These factors include the following requirements:

- Power specifications and requirements for the device
- Electrical wiring guidelines for the device installation site
- Power, connection, and power cord specifications for the device
- Grounding guidelines and specifications for the device

- Related Topics**
- General Site Guidelines for Installing the J-SRX240 Services Gateway on page 38
 - J-SRX240 Services Gateway Rack Requirements on page 39
 - Clearance Requirements for Airflow and Hardware Maintenance on the J-SRX240 Services Gateway on page 40
 - J-SRX240 Services Gateway Network Cable Requirements and Specifications on page 41

J-SRX240 Services Gateway Network Cable Requirements and Specifications

The J-SRX240 Services Gateway supports interfaces that use various kinds of cables and wires.

- Related Topics**
- General Site Guidelines for Installing the J-SRX240 Services Gateway on page 38
 - J-SRX240 Services Gateway Rack Requirements on page 39
 - Interface Cable and Wire Specifications for the J-SRX240 Services Gateway on page 127

- J-SRX240 Services Gateway Electrical and Power Requirements on page 41

CHAPTER 7

Installation Overview for the J-SRX240 Services Gateway

This chapter includes the following topic:

- Installation Overview for the J-SRX240 Services Gateway on page 44

Installation Overview for the J-SRX240 Services Gateway

After you have prepared your installation site, you are ready to unpack and install the services gateway. It is important to proceed through the installation process as shown in Table 21 on page 44.

Table 21: Installation Process Order for the J-SRX240 Services Gateway

Steps	Process	For more information, see
1	Review the safety guidelines.	"J-SRX240 Services Gateway Safety Requirements, Warnings, and Guidelines" on page 51
2	Verify that you have prepared your site for the installation of the services gateway using the checklist.	"Site Preparation Checklist for the J-SRX240 Services Gateway" on page 37
3	Unpack the services gateway and verify that the parts are received.	"Unpacking the J-SRX240 Services Gateway" on page 47
4	Prepare the services gateway for installation.	"Preparing the J-SRX240 Services Gateway for Installation" on page 51
5	Install the services gateway.	"Installing the J-SRX240 Services Gateway" on page 52
6	Connect cables to external devices.	"Connecting and Organizing Interface Cables to the J-SRX240 Services Gateway" on page 56
7	Connect the grounding cable.	"Grounding the J-SRX240 Services Gateway" on page 57
8	Power on the services gateway.	"Powering On and Powering Off the J-SRX240 Services Gateway" on page 59

- Related Topics**
- J-SRX240 Services Gateway Safety Requirements, Warnings, and Guidelines on page 51
 - General Site Guidelines for Installing the J-SRX240 Services Gateway on page 38
 - Unpacking the J-SRX240 Services Gateway on page 47
 - Preparing the J-SRX240 Services Gateway for Installation on page 51
 - Connecting and Organizing Interface Cables to the J-SRX240 Services Gateway on page 56
 - Grounding the J-SRX240 Services Gateway on page 57
 - Powering On and Powering Off the J-SRX240 Services Gateway on page 59

CHAPTER 8

Required Tools and Parts for Installing and Maintaining the J-SRX240 Services Gateway

This chapter includes the following topic:

- Required Tools and Parts for Installing and Maintaining the J-SRX240 Services Gateway on page 45

Required Tools and Parts for Installing and Maintaining the J-SRX240 Services Gateway

Table 22 on page 45 lists the tools and equipments required to install and maintain the J-SRX240 Services Gateway.

Table 22: Required Tools and Parts for Installing and Maintaining the J-SRX240 Services Gateway

Task	Tools and Parts	Related Topic
Installing the J-SRX240 Services Gateway	<ul style="list-style-type: none">• Phillips (+) screwdriver, number–2• Tie wrap	"Installing the J-SRX240 Services Gateway" on page 52
Connecting the J-SRX240 Services Gateway	Electrostatic discharge (ESD) grounding wrist strap	"Connecting the J-SRX240 Services Gateway to the Power Supply" on page 55
Grounding the J-SRX240 Services Gateway	Phillips (+) screwdrivers, numbers 1 and 2	"Grounding the J-SRX240 Services Gateway" on page 57
Packing the J-SRX240 Services Gateway	<ul style="list-style-type: none">• Blank panels to cover empty slots• Electrostatic bag or antistatic mat, for each component• Electrostatic discharge (ESD) grounding wrist strap	"Packing the J-SRX240 Services Gateway and Components for Shipment" on page 136

- Related Topics**
- Unpacking the J-SRX240 Services Gateway on page 47
 - Installing the J-SRX240 Services Gateway on page 52

- [Grounding the J-SRX240 Services Gateway on page 57](#)
- [Connecting the J-SRX240 Services Gateway to the Power Supply on page 55](#)
- [Packing the J-SRX240 Services Gateway and Components for Shipment on page 136](#)

CHAPTER 9

Unpacking the J-SRX240 Services Gateway

This chapter includes the following topics:

- Unpacking the J-SRX240 Services Gateway on page 47
- Verifying Parts Received with the J-SRX240 Services Gateway on page 47

Unpacking the J-SRX240 Services Gateway

The J-SRX240 Services Gateway is shipped in a cardboard carton and secured with foam packing material. The carton also contains an accessory box and the *J-SRX240 Services Gateway Quick Start Guide*.



NOTE: The device is maximally protected inside the shipping crate. Do not unpack it until you are ready to begin installation.

To unpack the services gateway:

1. Open the box in which the device is shipped.
2. Verify the parts received as in the list provided in Verifying Parts Received topic. See Related Topics.
3. Store the shipping box and packing material in case you need to return or move the device at a later time.

- Related Topics**
- Required Tools and Parts for Installing and Maintaining the J-SRX240 Services Gateway on page 45
 - Verifying Parts Received with the J-SRX240 Services Gateway on page 47
 - Preparing the J-SRX240 Services Gateway for Installation on page 51

Verifying Parts Received with the J-SRX240 Services Gateway

The J-SRX240 Services Gateway shipment package contains a packing list that includes all parts and accessories available with the device. Check the parts in the shipment

against the items on the packing list. The packing list specifies the part numbers and descriptions of each part in your order.



NOTE: If any part is missing, contact your Dell Support representative.

A fully configured J-SRX240 Services Gateway contains the chassis with installed components, listed in Table 23 on page 48 and an accessory box, which contains the parts listed in Table 24 on page 48.



NOTE: The parts shipped with your device can vary depending on the configuration you ordered.

Table 23: Parts List for a Fully Configured J-SRX240 Services Gateway

Component	Quantity
<ul style="list-style-type: none"> • For Low Memory model (J-SRX240B): J-SRX240 Services Gateway with 16xGE ports, 4xMini-PIM slots, and base memory (512 MB RAM, 1 GB Flash) • For High Memory model (J-SRX240H): J-SRX240 Services Gateway with 16xGE ports, 4xMini-PIM slots, and high memory (1 GB RAM, 1 GB Flash) • For PoE model (J-SRX240H-POE): J-SRX240 Services Gateway with 16xGE ports, 4xMini-PIM slots, and high memory (1 GB RAM, 1 GB Flash), 16 ports of POE 802.3at (150 watts across 16 ports) • For Voice model (J-SRX240H-P-MGW): J-SRX240 Services Gateway with 16xGE ports, 4xMini-PIM slots, and base memory (1 GB RAM, 1 GB Flash), 16 ports of POE (150 watts) and Media Gateway with 2 FXO and 2 FXS ports 	1
Rack Mounting Kit	1
3-Prong Power Cord	1
DB-9 to RJ-45 Adapter, Straight Through, 7 feet	1

Table 24: Accessory Parts List for the J-SRX240 Services Gateway

Part	Quantity
Product Warranty	1
End User License Agreement	1
Quick Start Guide	1
Security Products Safety Guide	1
Compliance Form Letter	1
Product Registration	1

- Related Topics**
- Unpacking the J-SRX240 Services Gateway on page 47
 - Preparing the J-SRX240 Services Gateway for Installation on page 51
 - Installing the J-SRX240 Services Gateway on page 52

CHAPTER 10

Installing the J-SRX240 Services Gateway

This chapter includes the following topics:

- J-SRX240 Services Gateway Safety Requirements, Warnings, and Guidelines on page 51
- Preparing the J-SRX240 Services Gateway for Installation on page 51
- Installing the J-SRX240 Services Gateway on page 52
- Replacing or Installing Mini-Physical Interface Modules in the J-SRX240 Services Gateway on page 54

J-SRX240 Services Gateway Safety Requirements, Warnings, and Guidelines

To avoid harm to yourself or the device as you install and maintain it, follow the guidelines for working with and near electrical equipment, as well as the safety procedures for working with devices. For a discussion of how to make the installation site a safe environment and a list of safety warnings, see the Appendix A for “Safety and Regulatory Compliance Information” on page 99.



NOTE: Providing an exhaustive set of guidelines for working with electrical equipment is beyond the scope of this guide.

Related Topics

- Preparing the J-SRX240 Services Gateway for Installation on page 51
- Installing the J-SRX240 Services Gateway on page 52

Preparing the J-SRX240 Services Gateway for Installation

You can mount a J-SRX240 Services Gateway in a rack. The services gateway can be mounted on four-post (telco) racks, enclosed cabinets, and open-frame racks.



NOTE: The J-SRX240 Services Gateway does not support center-mount racks.

Table 25: J-SRX240 Services Gateway Preinstallation Checklist

Task	Additional Information
Verify that the installation site meets the requirements	"General Site Guidelines for Installing the J-SRX240 Services Gateway" on page 38.
Remove the services gateway chassis from the shipping carton	"Unpacking the J-SRX240 Services Gateway" on page 47.
Verify the parts you have received	"Verifying Parts Received with the J-SRX240 Services Gateway" on page 47.
Verify that the following contents are available in the supplied mounting kit: <ul style="list-style-type: none"> Rack-mounting brackets Mounting screws 	"Verifying Parts Received with the J-SRX240 Services Gateway" on page 47.

- Related Topics**
- General Site Guidelines for Installing the J-SRX240 Services Gateway on page 38
 - Unpacking the J-SRX240 Services Gateway on page 47
 - Verifying Parts Received with the J-SRX240 Services Gateway on page 47
 - Installing the J-SRX240 Services Gateway on page 52

Installing the J-SRX240 Services Gateway

You can front-mount the J-SRX240 Services Gateway in a rack.



NOTE: If you are installing multiple devices in one rack, install the lowest one first and proceed upward in the rack.



NOTE: Remove the rubber feet from the base of the chassis for rack installation.

To install the device in a rack:

1. Position a mounting bracket on each side of the chassis as shown in Figure 10 on page 53.

Figure 10: Installing the J-SRX240 Services Gateway in a Rack

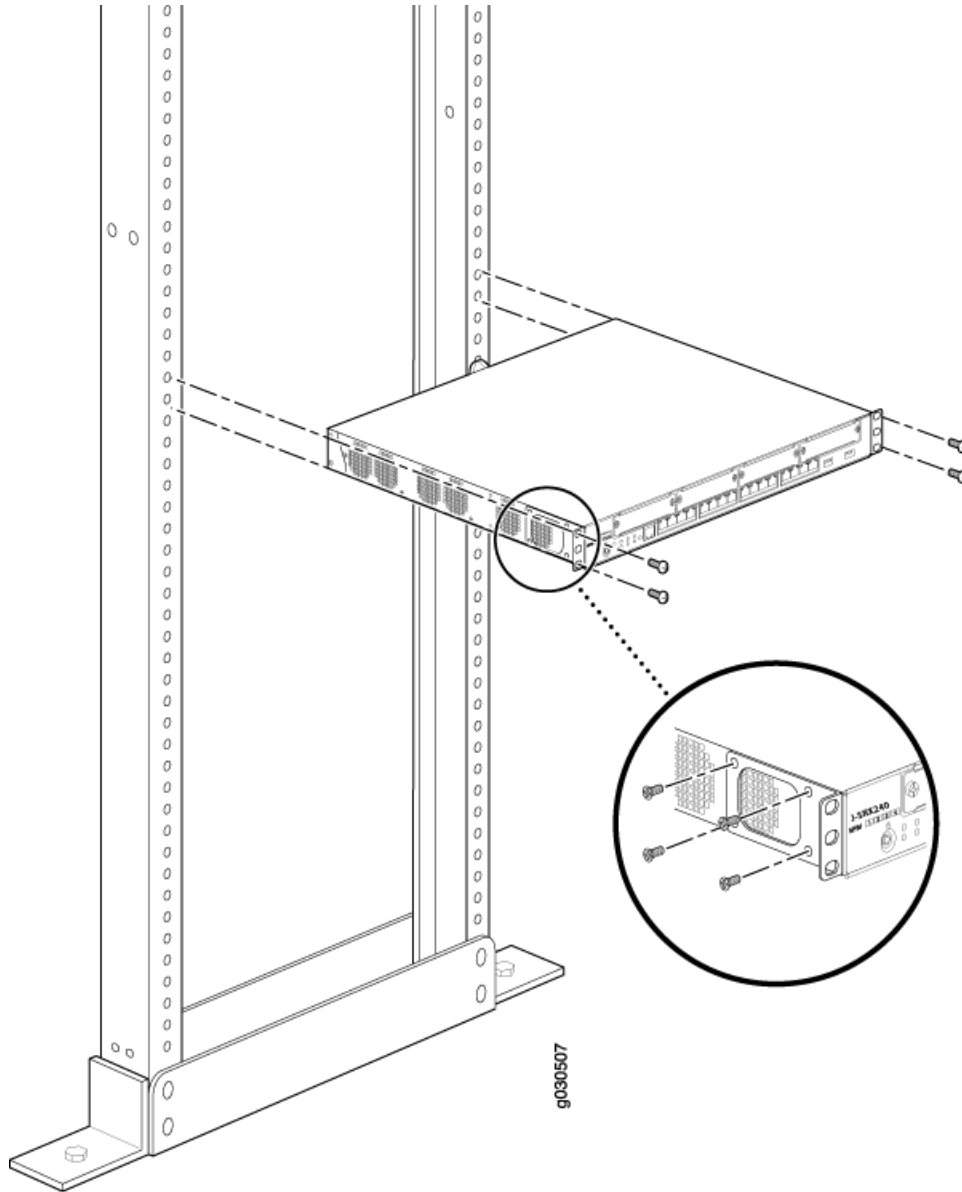

2. Use a number-2 Phillips screwdriver to install the screws that secure the mounting brackets to the chassis.
3. Have one person grasp the sides of the device, lift it, and position it in the rack.
4. Align the bottom hole in each mounting bracket with a hole in each rack rail, making sure the chassis is level.
5. Have a second person install a mounting screw into each of the two aligned holes. Use a number-2 Phillips screwdriver to tighten the screws.

6. Install the second screw in each mounting bracket.
7. Verify that the mounting screws on one side of the rack are aligned with the mounting screws on the opposite side and that the device is level.

- Related Topics**
- [Preparing the J-SRX240 Services Gateway for Installation on page 51](#)
 - [Required Tools and Parts for Installing and Maintaining the J-SRX240 Services Gateway on page 45](#)
 - [J-SRX240 Services Gateway Installation Safety Guidelines and Warnings on page 106](#)

Replacing or Installing Mini-Physical Interface Modules in the J-SRX240 Services Gateway

Mini-Physical Interface Modules (Mini-PIMs) are circuit boards that you can install in a device for enhanced functionality based on your requirements. They enable you to easily add or change physical interfaces on a device.

The Mini-Physical Interface Module (Mini-PIM) slot is covered with a blank faceplate to maintain proper airflow through the services gateway. Before installing the Mini-PIM, you must remove the faceplate.

See the *PowerConnect J-SRX Series Services Gateways for the Branch Physical Interface Modules Hardware Guide* for information about installing the Mini-PIMs.



NOTE: The Mini-PIMs available on the J-SRX240 Services Gateway are not hot-swappable. You need to power off the device before removing or installing Mini-PIMs.

- Related Topics**
- [J-SRX240 Services Gateway Installation Safety Guidelines and Warnings on page 106](#)
 - [Required Tools and Parts for Installing and Maintaining the J-SRX240 Services Gateway on page 45](#)
 - [Installing the J-SRX240 Services Gateway on page 52](#)

CHAPTER 11

Connecting, Grounding, and Powering On the J-SRX240 Services Gateway

This chapter includes the following topics:

- Connecting the J-SRX240 Services Gateway to the Power Supply on page 55
- Connecting and Organizing Interface Cables to the J-SRX240 Services Gateway on page 56
- Grounding the J-SRX240 Services Gateway on page 57
- Powering On and Powering Off the J-SRX240 Services Gateway on page 59

Connecting the J-SRX240 Services Gateway to the Power Supply

Figure 11 on page 55 shows the J-SRX240 Services Gateway power supply connection.

Figure 11: J-SRX240 Services Gateway Power Supply Connection

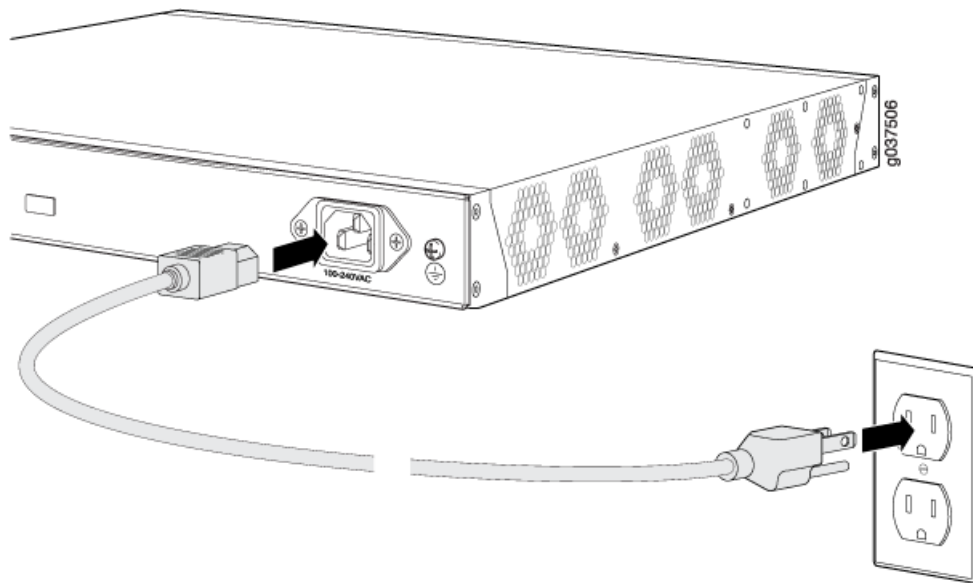

To connect the device to the power supply:

1. Attach an electrostatic discharge (ESD) grounding strap to your bare wrist, and connect the other end of the ESD strap to the ESD point on the rack.
2. Insert the appliance coupler end of a power cord into the appliance inlet on the power supply faceplate.
3. Insert the plug into an AC power source receptacle.



NOTE: The device must be connected to earth ground during normal operation. The protective earthing terminal on the rear of the chassis is provided to connect the device to ground.



CAUTION: We recommend using a surge protector for the power connection.



NOTE: Use the cable tie holder to secure the power cord on to the power supply point.

Related Topics

- Installing the J-SRX240 Services Gateway on page 52
- Required Tools and Parts for Installing and Maintaining the J-SRX240 Services Gateway on page 45
- Connecting and Organizing Interface Cables to the J-SRX240 Services Gateway on page 56
- Grounding the J-SRX240 Services Gateway on page 57
- Powering On and Powering Off the J-SRX240 Services Gateway on page 59

Connecting and Organizing Interface Cables to the J-SRX240 Services Gateway

Connecting the Interface Cables

You connect the interfaces installed in the services gateway to various network media. Each type of interface on a services gateway uses a particular medium to transmit data. You must configure each network interface before it can operate on the device.

To connect the interface cable to the device:

1. Have ready a length of the type of cable used by the interface.
2. Insert the cable connector into the cable connector port on the interface faceplate.



NOTE: External devices can be attached to console, Ethernet, or Gigabit Ethernet ports.

Organizing the Interface Cables

Arrange network cables as follows to prevent them from dislodging or developing stress points:

- Secure cables so that they are not supporting their own weight as they hang to the floor.
- Place excess cable out of the way in neatly coiled loops.
- Use fasteners to maintain the shape of cable loops.

- Related Topics**
- Installing the J-SRX240 Services Gateway on page 52
 - Grounding the J-SRX240 Services Gateway on page 57
 - Connecting the J-SRX240 Services Gateway to the Power Supply on page 55
 - Powering On and Powering Off the J-SRX240 Services Gateway on page 59

Grounding the J-SRX240 Services Gateway

To meet safety and electromagnetic interference (EMI) requirements and to ensure proper operation, you must adequately ground the J-SRX240 Services Gateway before connecting power.

Figure 12 on page 57 shows the J-SRX240 Services Gateway grounding point.

Figure 12: Grounding the J-SRX240 Services Gateway

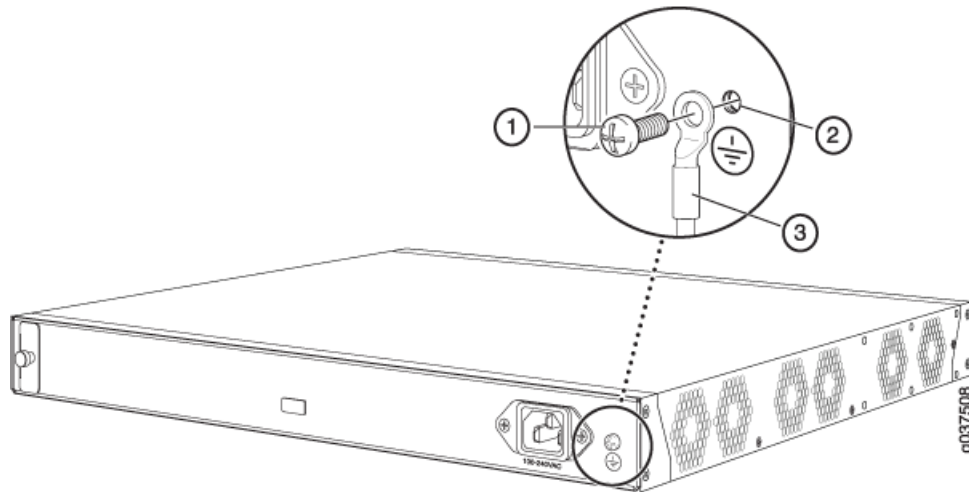

You ground the device by connecting a grounding cable to earth ground and then attaching it to the chassis grounding point using one 6–32 UNC screw.



CAUTION: Before you install the device, a licensed electrician must attach a cable lug to the grounding and power cables that you supply. A cable with an incorrectly attached lug can damage the device (for example, by causing a short circuit).



NOTE: The J-SRX240 Services Gateway is not NEBS-compliant.

Table 26 on page 58 lists the grounding components of the J-SRX240 Services Gateway.

Table 26: J-SRX240 Services Gateway Grounding Components

Number	Component
1	Grounding screw (6–32 UNC screw)
2	Grounding point on the chassis
3	Grounding lug

To ground the device:

1. Connect the grounding cable to a proper earth ground.
2. Verify that a licensed electrician has attached the cable lug to the grounding cable.
3. Place the grounding cable lug over the grounding point on the middle rear of the chassis.
4. Secure the grounding cable lug to the grounding point with the screw as shown in Figure 12 on page 57.
5. Dress the grounding cable and verify that it does not touch or block access to the services gateway components and that it does not cause anyone to trip on it.



NOTE: The device should be permanently connected to ground during operation.

Related Topics

- Installing the J-SRX240 Services Gateway on page 52
- Required Tools and Parts for Installing and Maintaining the J-SRX240 Services Gateway on page 45
- J-SRX240 Services Gateway Grounding Specifications on page 125
- Connecting and Organizing Interface Cables to the J-SRX240 Services Gateway on page 56
- Connecting the J-SRX240 Services Gateway to the Power Supply on page 55
- Powering On and Powering Off the J-SRX240 Services Gateway on page 59

Powering On and Powering Off the J-SRX240 Services Gateway

This topic describes the following procedures:

1. Powering On the J-SRX240 Services Gateway on page 59
2. Powering Off the J-SRX240 Services Gateway on page 59

Powering On the J-SRX240 Services Gateway

To power on the services gateway:

1. Ensure that you have connected the power supply to the device.
2. Insert the plug of the power supply adapter into an AC power source receptacle.
3. Turn on the power to the AC power receptacle and press the Power button.
4. The device starts as the power supply completes its startup sequence. The Power LED lights during startup and remains on steadily when the device is operating normally.



NOTE: After the power supply is turned on, it can take up to 60 seconds for status indicators—such as the Status LEDs on the power supply and the show chassis command display—to show that the power supply is functioning normally. Ignore error indicators that appear during the first 60 seconds.



NOTE: If the system is completely powered off when you turn on the power supply, the device starts as the power supply completes its startup sequence. If the device finishes starting and you need to power off the system again, first issue the CLI request `system power-off` command.

Powering Off the J-SRX240 Services Gateway

You can power off the services gateway in one of the following ways:

- Graceful shutdown—Press and immediately release the Power button. The device begins gracefully shutting down the operating system and then powers itself off.



WARNING: Use the graceful shutdown method to power off or reboot the services gateway.

- Immediate shutdown—Press the Power button and hold it for 10 seconds. The device immediately powers itself off without shutting down the operating system.



.....
WARNING: Use the immediate shutdown method as a last resort to recover the services gateway if the services gateway operating system is not responding to the graceful shutdown method.
.....



.....
WARNING: Do not press the Power button while the device is shutting down.
.....



.....
CAUTION: Immediate shutdown can result in data loss and corruption of the file system.
.....



.....
NOTE: To remove power completely from the device, unplug the power cord or switch off the AC power source.

After powering off a power supply, wait at least 10 seconds before turning it back on. After powering on a power supply, wait at least 10 seconds before turning it off.

The Power button on the services gateway is a standby power switch. If the services gateway is connected to a power source when you press the Power button to power the device off, the following happens:

- For immediate shutdown, 12 V power will still be available in the chassis and the device will be fully powered off.
- For graceful shutdown, the power will be on and the device will be in standby mode.



.....
TIP: For immediate restart, there is no hardware restart and the device is not powered off. To power off the device, the command needs to be provided through the software. The device software displays a message prompting you to remove the power cable. When the power cable is removed, the device is completely powered off.
.....



.....
NOTE: You can schedule a reboot to the services gateway using `request system reboot`.
.....

For more information about halting, powering off, or rebooting the services gateway using the CLI, see the *JUNOS Software Administration Guide*.

Related Topics

- Installing the J-SRX240 Services Gateway on page 52
- Required Tools and Parts for Installing and Maintaining the J-SRX240 Services Gateway on page 45
- Connecting and Organizing Interface Cables to the J-SRX240 Services Gateway on page 56
- Connecting the J-SRX240 Services Gateway to the Power Supply on page 55

J-SRX240 Services Gateway Autoinstallation

This chapter includes the following topic:

- J-SRX240 Services Gateway Autoinstallation Overview on page 61

J-SRX240 Services Gateway Autoinstallation Overview

The autoinstallation process begins any time a services gateway is powered on and cannot locate a valid configuration file in the internal flash. Typically, a configuration file is unavailable when a services gateway is powered on for the first time or if the configuration file is deleted from the internal flash. The autoinstallation feature enables you to deploy multiple services gateways from a central location in the network.

If you are setting up many devices, autoinstallation can help automate the configuration process by loading configuration files onto new or existing devices automatically over the network. You can use either the J-Web configuration editor or the CLI configuration editor to configure a device for autoinstallation.

For the autoinstallation process to work, you must store one or more host-specific or default configuration files on a configuration server in the network and have a service available—typically Dynamic Host Configuration Protocol (DHCP)—to assign an IP address to the services gateway.

Autoinstallation takes place automatically when you connect an Ethernet port on a new services gateway to the network and power on the device. To simplify the process, you can explicitly enable autoinstallation on a device and specify a configuration server, an autoinstallation interface, and a protocol for IP address acquisition.

For more information about configuring autoinstallation, see the *JUNOS Software Administration Guide*.

- Related Topics**
- Connecting the J-SRX240 Services Gateway to the Power Supply on page 55
 - Grounding the J-SRX240 Services Gateway on page 57
 - Powering On and Powering Off the J-SRX240 Services Gateway on page 59

CHAPTER 13

Connecting the J-SRX240 Services Gateway to Management Devices

This chapter includes the following topics:

- Connecting the J-SRX240 Services Gateway to the J-Web Interface on page 63
- Connecting the J-SRX240 Services Gateway to the CLI on page 66
- Connecting the Modem at the J-SRX240 Services Gateway End on page 68
- Connecting the Modem to the Console Port on the J-SRX240 Services Gateway on page 69
- Connecting to the CLI at the User End for the J-SRX240 Services Gateway on page 69

Connecting the J-SRX240 Services Gateway to the J-Web Interface

If you plan to use the J-Web interface to configure the services gateway, you must connect through one of the built-in Gigabit Ethernet management ports.

When the services gateway is powered on for the first time, the system looks for a DHCP server. If it does not find the system, the system assigns an IP address within the **192.168.1.0/24** subnetwork to any devices connected to gateway.

To connect to the J-Web interface through port 0 on the services gateway, see Figure 13 on page 64.

Figure 13: Connecting to the Ethernet Port on a J-SRX240 Services Gateway

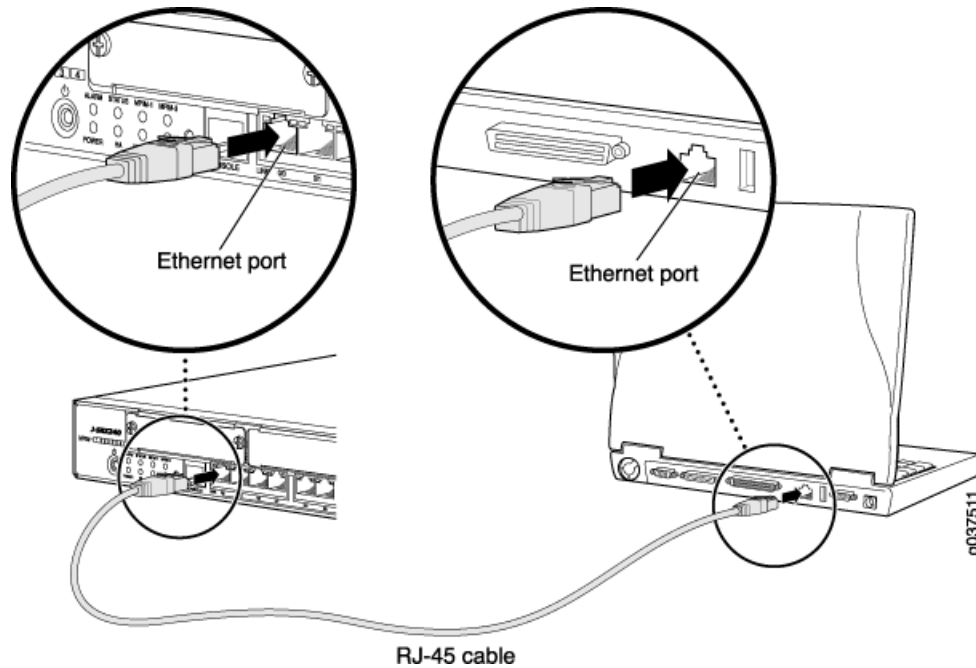

To connect to the Ethernet port:

1. From the management device you use to access the J-Web interface (such as a PC or a laptop), verify that the address of the port you connect to is set to one of the following values:
 - Ethernet address on the **192.168.1/24** subnetwork other than **192.168.1.1**
 - Ethernet address from a DHCP server
2. Plug one end of the Ethernet cable into the Ethernet port on the management device.
3. Connect the other end of the Ethernet cable to the built-in Gigabit Ethernet port on the services gateway.
4. Wait until the Status LED on the front panel turns solid green.
5. Turn on the power to the management device. The services gateway assigns an IP address to the management device within the **192.168.1.0/24** subnetwork if the services gateway is configured to use DHCP.
6. From the management device, open a Web browser and enter the IP address **192.168.1.1** in the address field.
7. Configure basic settings for your services gateway.



NOTE: You must manually configure the IP address for the management port you are using before you save your initial configuration. When you save the configuration for the first time, you will lose the connection to the services gateway if you have not manually configured the IP address. If you lose the connection through the management interface, you must connect through the Console port.

Related Topics

- Connecting the J-SRX240 Services Gateway to the CLI on page 66
- Connecting to the CLI at the User End for the J-SRX240 Services Gateway on page 69
- Connecting the Modem at the J-SRX240 Services Gateway End on page 68
- Connecting the Modem to the Console Port on the J-SRX240 Services Gateway on page 69

Connecting the J-SRX240 Services Gateway to the CLI

If you plan to use the CLI to configure the J-SRX240 Services Gateway, you must connect through the console port as shown in Figure 14 on page 66.

Figure 14: Connecting a J-SRX240 Services Gateway to the CLI

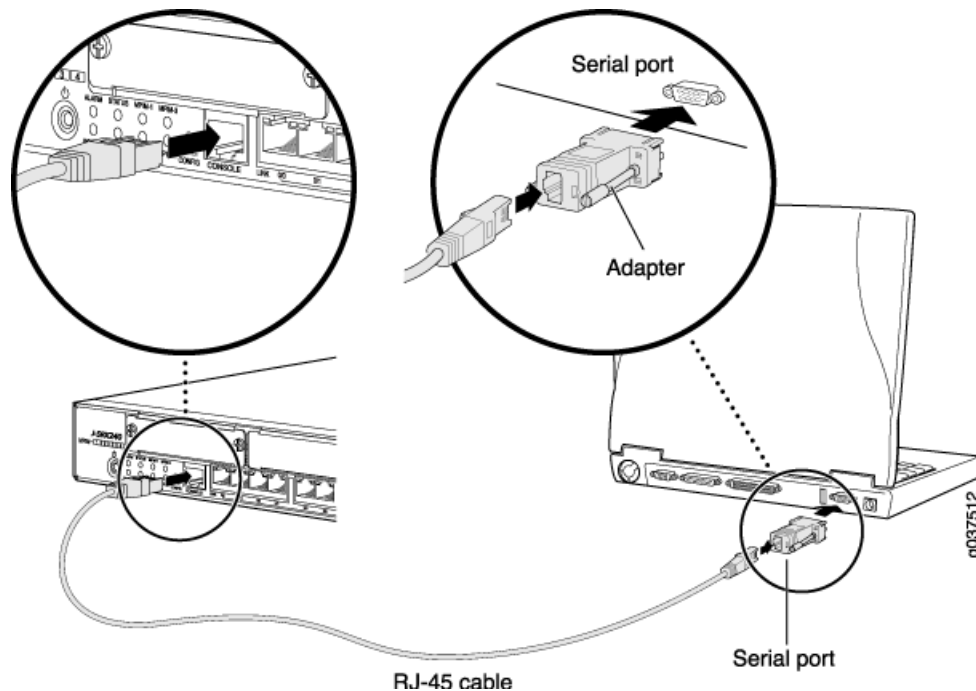

NOTE: The above figure shows a connection to a local management device. A remote connection to the services gateway through a modem requires the cable and connector shown (provided in the services gateway accessory box), plus a DB-9 female to DB-25 male (or similar) adapter for your modem, which you must purchase separately.

Connecting the Services Gateway to the CLI Locally

To connect to the CLI using a local management device through the console port on the services gateway:

1. Turn off power to the services gateway.
2. Turn off power to the management device, such as a PC or laptop computer, that you are using to access the CLI.
3. Plug one end of the Ethernet cable supplied with your services gateway into the RJ-45 to DB-9 serial port adapter supplied with your services gateway.
4. Plug the RJ-45 to DB-9 serial port adapter into the serial port on the management device.

5. Connect the other end of the Ethernet cable to the console port on the services gateway.
6. Turn on the power to the management device.
7. Start your asynchronous terminal emulation application (such as Microsoft Windows HyperTerminal) and select the appropriate **COM** port to use (for example, **COM1**).
8. Configure the port settings shown in Table 27 on page 67.

Table 27: Port Settings When Connecting the Services Gateway to the CLI Locally

Port Settings	Value
Bits per second	9600
Data bits	8
Parity	None
Stop bits	1
Flow control	None

9. Power on the services gateway by pressing the Power button on the front panel. Verify that the Power LED on the front panel turns green.

The terminal emulation screen on your management device displays the startup sequence. When the services gateway has finished starting up, a login prompt appears.
10. Log in as the user **root**. No password is required at initial connection, but you must assign a root password before committing any configuration settings.

Connecting a Services Gateway to the CLI Remotely

You can connect the services gateway to the CLI from a remote location through two dial-up modems:

- A modem that is connected to the console port on the services gateway
- A second modem connected to a remote management device

The modem connection allows you to remotely perform the same console operations you can perform locally.

Related Topics

- Connecting the J-SRX240 Services Gateway to the J-Web Interface on page 63
- Connecting to the CLI at the User End for the J-SRX240 Services Gateway on page 69
- Connecting the Modem at the J-SRX240 Services Gateway End on page 68
- Connecting the Modem to the Console Port on the J-SRX240 Services Gateway on page 69

Connecting the Modem at the J-SRX240 Services Gateway End

Before you can connect a dial-up modem to the console port on the J-SRX240 Services Gateway, you must configure the modem to accept a call on the first ring and accept DTR signals. You must also disable flow control on the modem.



NOTE: These instructions use Hayes-compatible modem commands to configure the modem. If your modem is not Hayes-compatible, refer to the documentation for your modem and enter the equivalent modem commands.

To configure the modem on the services gateway end:

1. Connect the modem to a PC or laptop computer.
2. Power on the modem.
3. From the PC or laptop computer, start your asynchronous terminal emulation application (such as Microsoft Windows HyperTerminal) and select the **COM** port to which the modem is connected (for example, **COM1**).
4. Configure the port settings shown in Table 28 on page 68.

Table 28: Port Settings to Configure the Modem on Services Gateway End

Port Settings	Value
Bits per second	9600
Data bits	8
Parity	None
Stop bits	1
Flow control	None

5. In the HyperTerminal window, enter **AT**.

For more information on the AT commands, see the *JUNOS Software Administration Guide*.

An **OK** response verifies that the modem can communicate successfully with the **COM** port on the PC or laptop.

6. Configure the modem to answer a call on the first ring, by entering **ATS0=1**.
7. Configure the modem to accept modem control DTR signals, by entering **AT&D1**.
8. Disable flow control, by entering **AT&K0**.
9. Save modem settings, by entering **AT&W**.

- Related Topics**
- Connecting the J-SRX240 Services Gateway to the J-Web Interface on page 63
 - Connecting the J-SRX240 Services Gateway to the CLI on page 66
 - Connecting to the CLI at the User End for the J-SRX240 Services Gateway on page 69
 - Connecting the Modem to the Console Port on the J-SRX240 Services Gateway on page 69

Connecting the Modem to the Console Port on the J-SRX240 Services Gateway

To connect the dial-up modem to the console port on the services gateway:

1. Turn off power to the services gateway.
2. Turn off power to the modem.
3. Plug one end of the Ethernet cable supplied with your services gateway into the console port (Figure 17 on page 129 shows the console cable connector) on the services gateway.
4. Plug the other end of the Ethernet cable into the RJ-45 to DB-9 serial port adapter supplied with your services gateway.
5. Connect the serial port adapter to a separately purchased DB-9 female to DB-25 male adapter or other adapter appropriate for your modem.
6. Plug the modem adapter into the DB-25 connector on the modem.
7. Connect the modem to your telephone network.
8. Turn on the power to the modem.
9. Power on the services gateway by pressing the Power button on the front panel. Verify that the **Power** LED on the front panel turns green.



NOTE: Most modems have an RS-232 DB-25 connector. You must separately purchase an adapter to connect your modem to the RJ-45 to DB-9 adapter and Ethernet cable supplied with the services gateway.

- Related Topics**
- Connecting the J-SRX240 Services Gateway to the J-Web Interface on page 63
 - Connecting the J-SRX240 Services Gateway to the CLI on page 66
 - Connecting the Modem at the J-SRX240 Services Gateway End on page 68
 - Connecting to the CLI at the User End for the J-SRX240 Services Gateway on page 69

Connecting to the CLI at the User End for the J-SRX240 Services Gateway

To remotely connect to the CLI through a dial-up modem connected to the console port on the services gateway:

1. Connect a modem at your remote location to a management device such as a PC or laptop computer.
2. Start your asynchronous terminal emulation application (such as Microsoft Windows HyperTerminal) on the PC or laptop computer.
3. Select the **COM** port to which the modem is connected (for example, **COM1**).
4. Configure the port settings shown in Table 29 on page 70.

Table 29: Port Settings for Connecting CLI at User End

Port Settings	Value
Bits per second	9600
Data bits	8
Parity	None
Stop bits	1
Flow control	None

5. In the HyperTerminal window, enter **AT**.
 For more information on the AT commands, see the *JUNOS Software Administration Guide*.
 An **OK** response verifies that the modem can communicate successfully with the **COM** port on the PC or laptop.
6. Dial the modem that is connected to the console port on the services gateway by entering **ATDT remote-modem-number**. For example, if the number of the modem connected to the console port on the services gateway is **0013033033030**, enter **ATDT 0013033033030**.
 The services gateway login prompt appears.
7. Log in as the user **root**. No password is required at initial connection, but you must assign a root password before committing any configuration settings.

Related Topics

- Connecting the J-SRX240 Services Gateway to the J-Web Interface on page 63
- Connecting the J-SRX240 Services Gateway to the CLI on page 66
- Connecting to the CLI at the User End for the J-SRX240 Services Gateway on page 69
- Connecting the Modem at the J-SRX240 Services Gateway End on page 68
- Connecting the Modem to the Console Port on the J-SRX240 Services Gateway on page 69

CHAPTER 14

Performing Initial Software Configuration on the J-SRX240 Services Gateway

This chapter includes the following topics:

- J-SRX240 Services Gateway Software Configuration Overview on page 71
- Performing Initial Software Configuration on the J-SRX240 Services Gateway Using the CLI on page 74
- Performing Initial Software Configuration on the J-SRX240 Services Gateway Using the J-Web Interface on page 76
- J-SRX240 Services Gateway Secure Web Access Overview on page 82

J-SRX240 Services Gateway Software Configuration Overview

This topic includes the following sections:

- Preparing J-SRX240 Services Gateway for Configuration on page 71
- Understanding Built-In Ethernet Ports on page 72
- Mapping the Chassis Cluster Ports on page 72
- Understanding Management Access on page 73

Preparing J-SRX240 Services Gateway for Configuration

The services gateway is shipped with the JUNOS Software preinstalled and ready to be configured when the device is powered on.

When the device boots, it first attempts to start the image on the USB flash drive. If a USB flash drive is not inserted into the Routing Engine or the attempt otherwise fails, the device next tries the CompactFlash card (if installed), and finally the hard disk.

You configure the services gateway by issuing JUNOS command-line interface (CLI) commands.

Gather the following information before configuring the device:

- Device name to be used on the network
- Domain name the device will use

- IP address and prefix length information for the Ethernet interface
- IP address of a default router
- IP address of a DNS server
- Password for the root user

Understanding Built-In Ethernet Ports

Note the following points about the J-SRX240 Services Gateway management port:

- The J-SRX240 Services Gateway uses any of the ports between **ge-0/0/1** and **ge-0/0/15** as a management port to perform initial device setup. Before initial configuration, when the factory default configuration is active, the device attempts to perform autoinstallation by obtaining a device configuration through all of its connected interfaces.
- The services gateway acts as a DHCP client out of the built-in Ethernet ports. If the services gateway does not find a DHCP server within a few seconds, the device acts as a DHCP server and assigns an IP address as 192.168.1.1/24. With the device temporarily acting as a DHCP server, you can manually configure it with the J-Web interface.
- Any DHCP client host, for example, a PC or laptop computer, directly connected to any of the ports between **ge-0/0/1** and **ge-0/0/15** receives an address on the 192.168.1.1/24 network.

Mapping the Chassis Cluster Ports

On the J-SRX240 Services Gateway, the following ports are not user configurable when the services gateway is operating in chassis cluster mode.

The **fxp0** port is dedicated as the out-of-band management interface for each of the devices in the chassis cluster setup and the **fxp1** port is dedicated as the chassis-cluster control port.

Table 30 on page 72 shows the mapping of the chassis cluster ports.

Table 30: Mapping the Chassis Cluster Ports on a J-SRX240 Services Gateway

GE Ports on J-SRX240 Services Gateway	Management Interface
ge-0/0/0	fxp0 (management port)
ge-0/0/1	fxp1 (control port)

JUNOS Software automatically creates the **fxp0** and **fxp1** interfaces on these ports when the J-SRX240 Services Gateway is operating in chassis cluster mode.

For more information, see the following guides:

- *JUNOS Software Interfaces and Routing Configuration Guide*

- *JUNOS Software Security Configuration Guide*

Understanding Management Access

Telnet allows you to connect to the services gateway and access the CLI to execute commands from a remote system. Telnet CLI connections are not encrypted and therefore can be intercepted.



NOTE: Telnet access to the root user is prohibited. You must use more secure methods, such as SSH, to log in as root.

SSH provides the following features:

- Allows you to connect to the device and access the CLI to execute commands from a remote system
- Encrypts traffic so that it cannot be intercepted (unlike Telnet)
- Can be configured so that connections are authenticated by a digital certificate
- Uses public–private key technology for both connection and authentication

The SSH client software must be installed on the machine where the client application runs. If the SSH private key is encrypted (for greater security), the SSH client must be able to access the passphrase used to decrypt the key.

For information about obtaining SSH software, see <http://www.ssh.com> and <http://www.openssh.com>.

If you are using a JUNOScript server to configure and monitor devices, you can activate cleartext access on the device to allow unencrypted text to be sent directly over a Transmission Line Protocol (TCP) connection without using any additional protocol (such as SSH, SSL, or Telnet). For more information about the JUNOScript application programming interface (API), see the *JUNOS Software JUNOScript API Guide*.



NOTE: Information sent in cleartext is not encrypted and therefore can be intercepted.

If the device is operating in a Common Criteria environment, see the *Secure Configuration Guide for Common Criteria and JUNOS-FIPS*.

Related Topics

- Connecting the J-SRX240 Services Gateway to the J-Web Interface on page 63
- Connecting the J-SRX240 Services Gateway to the CLI on page 66
- Performing Initial Software Configuration on the J-SRX240 Services Gateway Using the CLI on page 74
- Performing Initial Software Configuration on the J-SRX240 Services Gateway Using the J-Web Interface on page 76
- J-SRX240 Services Gateway Secure Web Access Overview on page 82

Performing Initial Software Configuration on the J-SRX240 Services Gateway Using the CLI

This procedure connects the device to the network but does not enable it to forward traffic. For complete information about enabling the device to forward traffic, including examples, see the appropriate JUNOS Software configuration guides.

To configure the software:

1. Verify that the device is powered on.
2. Log in as the root user. There is no password.
3. Start the CLI.

```
root# cli
root@>
```
4. Enter configuration mode.

```
configure
[edit]
root@#
```
5. Set the root authentication password by entering a cleartext password, an encrypted password, or an SSH public key string (DSA or RSA).

```
[edit]
root@# set system root-authentication plain-text-password
New password: password
Retype new password: password
```
6. Configure an administrator account on the device.

```
[edit]
root@# set system login user admin class super-user authentication
plain-text-password
```
7. Commit the configuration to activate it on the device.

```
[edit]
root@# commit
```
8. Log in as the administrative user you configured in Step 6.
9. Configure the name of the device. If the name includes spaces, enclose the name in quotation marks (" ").

```
configure
[edit]
admin@# set system host-name host-name
```
10. Configure the traffic interface.

```
[edit]
admin@# set interfaces ge-0/0/0 unit 0 family inet address address/prefix-length
admin@# set interfaces ge-0/0/1 unit 0 family inet address address/prefix-length
```

11. Configure the default route.

```
[edit]
admin@# set routing-options static route 0.0.0.0/0 next-hop gateway
```

12. Configure basic security zones and bind them to traffic interfaces.

```
[edit]
admin@# set security zones security-zone trust interfaces ge-0/0/0
admin@# set security zones security-zone untrust interfaces ge-0/0/1
```

13. Configure basic security policies.

```
[edit]
admin@# set security policies from-zone trust to-zone untrust policy policy-name
match source-address any destination-address any application any
root@# set security policies from-zone trust to-zone untrust policy policy-name then
permit
```

14. Create a NAT rule for source translation of all internet bound traffic.

```
[edit]
admin@# set security nat source rule-set interface-nat from zone trust
admin@# set security nat source rule-set interface-nat to zone untrust
admin@# set security nat source rule-set interface-nat rule rule1 match
source-address 0.0.0.0/0 destination-address 0.0.0.0/0
admin@# set security nat source rule-set interface-nat rule rule1 then source-nat
interface
```

15. Check the configuration for validity.

```
[edit]
admin@# commit check
configuration check succeeds
```

16. Commit the configuration to activate it on the device.

```
[edit]
admin@# commit
commit complete
```

17. Optionally, display the configuration to verify that it is correct.

```
[edit]
user@host# show
system {
  host-name devicea;
  domain-name lab.device.net;
  domain-search [ lab.device.net device.net ];
  backup-device 192.168.2.44;
  time-zone America/Los_Angeles;
  root-authentication {
    ssh-rsa "ssh-rsa AAAAB3Nza...D9Y2gXF9ac==root@devicea.lab.device.net";
  }
  name-server {
    10.148.2.32;
  }
  services {
  }
  ntp {
    server 10.148.2.21;
```

```
    }  
  }  
  interfaces {  
    ge-0/0/0 {  
      unit 0 {  
        family inet {  
          address 192.168.1.1/24;  
        }  
      }  
    }  
    lo0 {  
      unit 0 {  
        family inet {  
          address 172.16.1.24/32;  
        }  
      }  
    }  
  }  
}
```

18. Commit the configuration to activate it on the device.

```
[edit]  
admin@# commit
```

19. Optionally, configure additional properties by adding the necessary configuration statements. Then commit the changes to activate them on the device.

```
[edit]  
admin@host# commit
```

20. When you have finished configuring the device, exit configuration mode.

```
[edit]  
admin@host# exit  
admin@host>
```

- Related Topics**
- [Connecting the J-SRX240 Services Gateway to the CLI on page 66](#)
 - [J-SRX240 Services Gateway Software Configuration Overview on page 71](#)
 - [Performing Initial Software Configuration on the J-SRX240 Services Gateway Using the J-Web Interface on page 76](#)
 - [J-SRX240 Services Gateway Secure Web Access Overview on page 82](#)

Performing Initial Software Configuration on the J-SRX240 Services Gateway Using the J-Web Interface

This topic includes the following sections:

- [Establishing Basic Connectivity on page 77](#)
- [Configuring Basic System Properties on page 78](#)

Establishing Basic Connectivity

To establish basic connectivity:

1. Connect an Ethernet cable from any of the ports between **ge-0/0/0** and **ge-0/0/15** to the Ethernet port on the management device (workstation or laptop).
2. Connect the power cable to the device and a power source. (We recommend using a surge protector.) Note the following indications:
 - Power LED (solid green): The device is receiving power.
 - Status LED (solid green): The device is operating normally.



NOTE: The services gateway functions as a DHCP server and will assign an IP address to the management device.

3. Ensure that the management device acquires an IP address on the 192.168.1/24 subnetwork (other than 192.168.1.1) from the device.



NOTE: If an IP address is not assigned to the management device, manually configure an IP address in the 192.168.1/24 subnetwork. Do not assign the 192.168.1.1 IP address to the management device, as this IP address is assigned to the device.

4. Access the J-Web interface:
 - a. Launch a Web browser from the management device.
 - b. Enter 192.168.1.1 in the Address box.
 - c. Specify the default user name as root. Do not enter any value in the Password box.
 - d. Press Enter. The J-Web Initial Setup page is displayed.
5. Configure the basic settings such as Host Name, Domain Name, Root Password, and IP Address for your services gateway. Ensure that you have configured the IP address, root authentication, and default gateway before you apply the configuration.



NOTE: All network and management access settings are optional.

6. Click **Apply** to apply the configuration.



NOTE: After configuring the basic settings, the Web session may time out. Refresh or relaunch the page if the applied configuration page is not displayed.

Configuring Basic System Properties

To configure basic system properties:

1. In the J-Web interface, select **Configure > System properties** and select the required tab and proceed with configuring the other settings. Table 31 on page 78 provides the summary of configuration details for initial setup.

Table 31: Basic Configuration Summary

Field	Function	Your Action
Identification		
Host Name	Defines the hostname of the services gateway.	Type the hostname.
Domain Name	Defines the network or subnetwork that the services gateway belongs to.	Type the domain name.
Root Password (required)	Sets the password that user root can use to log into the services gateway.	Type a plaintext password that the system encrypts. NOTE: After a root password has been defined, it is required when you log into the J-Web user interface or the CLI.
Verify Root Password (required)	Verifies the root password has been typed correctly.	Retype the password.
DNS Name Servers	Specifies a DNS server that the services gateway can use to resolve hostnames into addresses.	Add an IP address by selecting it in the box to the left of the Add button, then clicking Add . Delete an IP address by clicking it in the box above the Add button, then clicking Remove .
Domain Search	Adds each domain name that includes the services gateway to the configuration so that each domain is included in a DNS search.	Add a domain name by typing it in the box to the left of the Add button, then clicking Add . Delete a domain name by clicking it in the box above the Add button, then clicking Remove .
Management Access		

Table 31: Basic Configuration Summary (*continued*)

Field	Function	Your Action
Default Gateway	Defines a default gateway through which to direct packets addressed to networks not explicitly listed in the routing table.	Type a 32-bit IP address in dotted decimal notation.
Loopback Address	Defines a reserved IP address that is always available on the services gateway. If no address is entered, this address is set to 127.0.0.1/32 .	Type a 32-bit IP address and prefix length in dotted decimal notation.
Allow Telnet Access	Allows remote access to the services gateway using Telnet.	Enable Telnet access by selecting the box.
Allow JUNOScript over Clear-Text Access	Allows JUNOScript to access the services gateway using a protocol for sending unencrypted text over a TCP connection.	Enable JUNOScript access over cleartext by selecting the box.
Allow SSH Access	Allows remote access to the services gateway using SSH.	Enable SSH access by selecting the box.
Date and Time		
Time Zone	Identifies the time zone in which the services gateway is located.	From the list, select the appropriate time zone.
NTP Servers	Specifies an NTP server that the services gateway can reach to synchronize the system time.	Add an IP address by clicking Add and in the box enter IP address, then click OK . Delete an IP address by clicking it in the box and then clicking Delete .

Table 31: Basic Configuration Summary (*continued*)

Field	Function	Your Action
Current System Time	Synchronizes the system time with the NTP server or allows you to manually set the system time and date.	<ul style="list-style-type: none"> Set the time immediately using the NTP server; select NTP Servers. The services gateway sends a request to the NTP server and synchronizes the system time. <p>NOTE: If you are configuring other settings on this page, the services gateway also synchronizes the system time using the NTP server when you click OK.</p> <ul style="list-style-type: none"> Set the time manually by selecting the Manual button. A window allows you to select the current date and time from lists.

2. Click one of the following buttons:
 - Click **OK** to save the changes.
 - Click **Cancel** to cancel your entries and return to the previous page.
 - Click **Commit** to apply the configuration and other pending changes (if any) and click **Discard** to discard pending changes.
3. Configure an interface as follows:
 - a. In the J-Web interface, select **Configure>Interfaces**.
The Interfaces page appears and lists the network interfaces present on the services gateway.
 - b. Under the Interface Name column, click the interface you want to configure (for example, ge-0/0/0).
 - c. Under Logical Interfaces, click **Add**.
 - d. Under IPv4 Addresses and Prefixes, click **Add**.

- e. In the IPv4 Address and Prefix boxes, enter an IP address and a subnet mask.
 - f. Click **OK**. The configured IP address is included in the Address Prefix column.
4. Configure the default route as follows
 - a. In the J-Web interface, select **Configure>Routing>Static routing**.
 - b. In the Static Routing page, click **Add**.
 - c. Add an IP address for Route and Next-hop.
 - d. Click **OK**. The configured IP address is included in the Static Routing page.
 5. Configure basic security zones and bind them to traffic interfaces.
 - a. In the J-Web interface, under the Configure tab, navigate to **Security > Zones**.
 - b. Under Security Zone, click **Add**.
 - c. Enter a name for the zone in the Zone Name box.
 - d. Scroll down to the Interfaces Configuration panel on the page to add an interface to a specific zone.
 - e. Click **OK** to save the configuration.
 6. Configure basic security policies.
 - a. In the J-Web interface, under the Configure tab, navigate to **Security > Policy**.
 - b. In the Security Policy page, click **Add**.
 - c. Enter a name for the policy and select the source and destination zones.
 - d. Enter a source address, destination address, and an application.
 - e. For the policy action, select one of these options: **Permit**, **Deny**, or **Reject**.
 - f. Click **OK** to save the configuration.



NOTE: Click **Commit** to apply the configuration and other pending changes (if any) and click **Discard** to discard pending changes.

For more instructions on managing users and operations, monitoring network performance, upgrading software, and diagnosing common problems on J-SRX240 Series Services Gateways, see the *JUNOS Software Administration Guide*.

Related Topics

- Connecting the J-SRX240 Services Gateway to the J-Web Interface on page 63
- J-SRX240 Services Gateway Software Configuration Overview on page 71
- Performing Initial Software Configuration on the J-SRX240 Services Gateway Using the CLI on page 74

- J-SRX240 Services Gateway Secure Web Access Overview on page 82

J-SRX240 Services Gateway Secure Web Access Overview

You can manage a services gateway remotely through the J-Web interface. To communicate with the services gateway, the J-Web interface uses Hypertext Transfer Protocol (HTTP). HTTP allows easy Web access but no encryption. The data that is transmitted between the Web browser and the services gateway by means of HTTP is vulnerable to interception and attack. To enable secure Web access, a services gateway supports HTTP over Secure Sockets Layer (HTTPS). You can enable HTTP or HTTPS access on specific interfaces and ports as needed.

The services gateway uses the SSL protocol to provide secure management of services gateways through the Web interface. SSL uses public-private key technology that requires a paired private key and an authentication certificate for providing the SSL service. SSL encrypts communication between your device and the Web browser with a session key negotiated by the SSL server certificate.

An SSL certificate includes identifying information such as a public key and a signature made by a certificate authority (CA). When you access the services gateway through HTTPS, an SSL handshake authenticates the server and the client and begins a secure session. If the information does not match or the certificate has expired, your access to the services gateway through HTTPS is restricted.

Without SSL encryption, communication between your services gateway and the browser is sent in the open and can be intercepted. We recommend that you enable HTTPS access on your WAN interfaces.

For more details about configuring the secure Web access, see the *JUNOS Software Administration Guide*.

- Related Topics**
- J-SRX240 Services Gateway Software Configuration Overview on page 71
 - Performing Initial Software Configuration on the J-SRX240 Services Gateway Using the CLI on page 74
 - Performing Initial Software Configuration on the J-SRX240 Services Gateway Using the J-Web Interface on page 76

PART 3

Maintaining, Replacing, and Monitoring the J-SRX240 Services Gateway Hardware

- Maintaining the J-SRX240 Services Gateway Hardware Components on page 85
- Monitoring the J-SRX240 Services Gateway on page 87

CHAPTER 15

Maintaining the J-SRX240 Services Gateway Hardware Components

This chapter includes the following topic:

- Maintaining the J-SRX240 Services Gateway Hardware Components on page 85

Maintaining the J-SRX240 Services Gateway Hardware Components

Table 32 on page 85 describes the common tasks to maintain the hardware components of the services gateway.

Table 32: Maintenance Procedures for the Services Gateway Hardware Components

Maintenance Procedures	Description
Routine Maintenance Procedures	<p>To maintain optimum performance of the services gateway, you should regularly perform the following preventive maintenance procedures:</p> <ul style="list-style-type: none">• Inspect the installation site for moisture, loose wires or cables, and excessive dust.• Make sure that airflow is unobstructed around the device and into the air intake vents.• Check the Status LED on the front panel of the device and on the Mini-Physical Interface Module (Mini-PIM) you are using.
Maintaining the Cooling System	<p>The services gateway cooling system works to maintain an optimal temperature for the device. If the fan controller fails, the device temperature will exceed the maximum working temperature and the device will fail. Ensure that you maintain the recommended clearances behind the device to enable the cooling system to function optimally.</p>

Table 32: Maintenance Procedures for the Services Gateway Hardware Components (continued)

Maintenance Procedures	Description
Maintaining the Power Supply	<p>To maintain the power supply on the services gateway:</p> <ul style="list-style-type: none">• Make sure that the power and grounding cables are arranged so that they do not obstruct access to other device components.• Periodically inspect the site to ensure that the grounding and power cables connected to the device are securely in place and that there is no moisture accumulating near the device. <p>CAUTION: We recommend using a surge protector for the power connection.</p>

- Related Topics**
- [Monitoring the J-SRX240 Services Gateway Components Using LEDs on page 89](#)
 - [Monitoring the J-SRX240 Services Gateway Using Chassis Alarm Conditions on page 92](#)
 - [Monitoring the J-SRX240 Services Gateway Power System on page 93](#)

CHAPTER 16

Monitoring the J-SRX240 Services Gateway

This chapter describes how to monitor J-SRX240 Services Gateway hardware components. If you encounter software problems, or problems with hardware components not discussed here, contact the Dell Support.

This chapter includes the following topics:

- Monitoring Hardware Components on the J-SRX240 Services Gateway on page 87
- Resetting the Configuration File When the J-SRX240 Services Gateway Is Inaccessible on page 94
- Dell Support on page 96

Monitoring Hardware Components on the J-SRX240 Services Gateway

This topic includes the following sections:

- Monitoring the J-SRX240 Services Gateway Chassis Using the CLI on page 87
- Monitoring the J-SRX240 Services Gateway Components Using LEDs on page 89
- Monitoring the J-SRX240 Services Gateway Using Chassis Alarm Conditions on page 92
- Monitoring the J-SRX240 Services Gateway Power System on page 93

Monitoring the J-SRX240 Services Gateway Chassis Using the CLI

You can monitor alarms to troubleshoot hardware problems on a services gateway. The chassis properties include the status of active chassis alarms on the device, environment measurements, and the status of Mini-PIMs on the device.

To view these chassis properties, select **Monitor>Chassis** in the J-Web interface, or enter the following CLI **show** commands:

- **show chassis hardware**
- **show chassis environment**
- **show chassis fpc**
- **show chassis alarms**

Examples:

The following examples provide the sample output of commands:

- **show chassis hardware** command

user@host > show chassis hardware

Item	Version	Part number	Serial number	Description
Chassis				SRX240-1m
Routing Engine	RER 00	750-021792	000000PS4650	RE-SRX240-LOWMEM
FPC 0				FPC
PIC 0				16x GE
FPC 1			112007000017	FPC
PIC 0				1x GE SFP mPIM
Xcvr 0		NON-JNPR	PC21HNK	SFP-SX
FPC 2				FPC
PIC 0				1x T1E1 mPIM
FPC 3			112007000038	FPC
PIC 0				1x GE SFP mPIM
Xcvr 0	REV 01	740-011614	6XS600H00049	SFP-LX10
FPC 4			112007000020	FPC
PIC 0				1x GE SFP mPIM
Xcvr 0	REV 01	740-011613	PAJ4SQ5	SFP-SX

The output sample shown in this example is for the J-SRX240 Services Gateway Low Memory version.

- **show chassis environment** command

user@host > show chassis environment

Class	Item	Status	Measurement
Temp	Routing Engine	Testing	
Fans	SRX240 Chassis fan	OK	(null)

- **show chassis fpc** command

user@host > show chassis fpc

Slot	State	Temp (C)	CPU Utilization (%)	Memory Utilization
		Total	Interrupt	DRAM (MB) Heap Buffer
0	Online	-----	CPU less	FPC -----
1	Online	-----	CPU less	FPC -----
2	Online	-----	CPU less	FPC -----
3	Online	-----	CPU less	FPC -----
4	Online	-----	CPU less	FPC -----

- **show chassis alarms** command

```
user@host > show chassis alarms
```

```
No alarms currently active
```

For more information, see the *JUNOS Software Administration Guide*.

- Related Topics**
- Monitoring the J-SRX240 Services Gateway Components Using LEDs on page 89
 - Monitoring the J-SRX240 Services Gateway Using Chassis Alarm Conditions on page 92
 - Monitoring the J-SRX240 Services Gateway Power System on page 93

Monitoring the J-SRX240 Services Gateway Components Using LEDs

The LEDs available on the services gateway display the status of various components. Table 33 on page 89 describes the LEDs.

Table 33: Component LEDs on the J-SRX240 Services Gateway

LED	State	Meaning	Possible Causes and Corrective Actions
Status LED	Green	The device is functioning normally.	Normal condition. No action is required.
	Amber	<ul style="list-style-type: none"> • The device is starting up. • The Reset Config button is pressed. 	Normal condition. No action is required.
	Red	An error is detected in the device.	Contact Dell Support. See “Dell Support” on page 96.
Alarm LED	Red	The device detects a major alarm.	A major alarm indicates a critical situation on the gateway that requires immediate action. See A “Monitoring the J-SRX240 Services Gateway Using Chassis Alarm Conditions” on page 92.
	Amber	<p>Indicates a minor alarm.</p> <p>NOTE: The Alarm LED glows Amber while initializing.</p>	A minor alarm requires monitoring or maintenance. If left unchecked, it might cause an interruption in service or degradation in performance. See “Monitoring the J-SRX240 Services Gateway Using Chassis Alarm Conditions” on page 92.
	Off	<p>The device is starting up.</p> <p>NOTE: When the system is up and running, if the Alarm LED is off, it indicates that no alarms are present on the device.</p>	Normal condition. No action is required.

Table 33: Component LEDs on the J-SRX240 Services Gateway (*continued*)

LED	State	Meaning	Possible Causes and Corrective Actions
Power LED	Green	The device is receiving power supply and is functioning normally.	Normal condition. No action is required.
	Amber	The Power button has been pressed and quickly released. The device is gracefully shutting down or starting up.	Normal condition. No action is required.
	Off	The device is not receiving power.	Normal condition if the services gateway is switched off. No action is required. If you have not powered off the services gateway, verify that the AC power cord from the power source to the device is not damaged, the socket is in working condition, and the device has an AC input voltage between 110 and 240 VAC. See "Monitoring the J-SRX240 Services Gateway Power System" on page 93.
HA LED	Off		The device is not part of the chassis cluster setup.
Mini-PIM LED	Green	The Mini-PIM is present and detected by the device.	Normal condition. No action is required.
	Off	The Mini-PIM is not present or is not detected by the device.	See "Monitoring the J-SRX240 Services Gateway Using Chassis Alarm Conditions" on page 92.

Table 33: Component LEDs on the J-SRX240 Services Gateway (*continued*)

LED	State	Meaning	Possible Causes and Corrective Actions
Voice Interface LED	Off	The port is inactive.	Normal condition. No action is required.
	Green (Steady)	The port is active and functioning normally.	Normal condition. No action is required.
	Amber	The port is active and not ready for data communication.	Normal condition. No action is required.
	Green (Blinking)	The port is active and data communication is taking place.	Normal condition. No action is required.
	Red (blinking)	The port is initializing. NOTE: The Voice Interface port LED glows red (blinking) while initializing. If there is an error, the LED remains red; otherwise, the LED changes to green.	Normal condition. No action is required.
	Red (steady)	The port has detected a hardware initialization failure.	Contact Dell Support. See “Dell Support” on page 96.

- Related Topics**
- Monitoring the J-SRX240 Services Gateway Chassis Using the CLI on page 87
 - Monitoring the J-SRX240 Services Gateway Using Chassis Alarm Conditions on page 92
 - Monitoring the J-SRX240 Services Gateway Power System on page 93
 - Using the Reset Config Button on the J-SRX240 Services Gateway on page 94
 - Changing the Reset Config Button Behavior on the J-SRX240 Services Gateway on page 95
 - Dell Support on page 96

Monitoring the J-SRX240 Services Gateway Using Chassis Alarm Conditions

When the services gateway detects an alarm condition, the Alarm LED on the front panel turns red or amber as appropriate.

To view a more detailed description of the cause of the alarm, issue the **show chassis alarms** CLI command.

For more information about the **show chassis alarms** command, see the *JUNOS Software Administration Guide*.

Table 34 on page 92 describes the chassis alarm conditions and corrective actions.

Table 34: J-SRX240 Services Gateway Chassis Alarm Conditions and Corrective Actions

Component	Alarm Condition	Action	Alarm Severity
Boot media	The services gateway boots from an alternate boot device.	<ul style="list-style-type: none"> • If the internal flash fails at startup, the services gateway automatically boots itself from the alternative boot device (USB storage device). <p>NOTE: If you configured your services gateway to boot from an alternative boot device, ignore this alarm condition.</p> <ul style="list-style-type: none"> • Reformat the internal flash and install a bootable image. (See the <i>JUNOS Software Administration Guide</i>.) • If you did not configure the services gateway to boot from an alternative boot device, contact Dell Support. See “Dell Support” on page 96. 	Amber (minor)
Mini-Physical Interface Module (Mini-PIM)	A Mini-PIM has failed.	<ul style="list-style-type: none"> • Contact Dell Support See “Dell Support” on page 96. • If you must replace the failed Mini-PIM, see the <i>J-SRX Series Services Gateways for the Branch Physical Interface Modules Hardware Guide</i> for information about replacing the Mini-PIMs. 	Red (major)

Table 34: J-SRX240 Services Gateway Chassis Alarm Conditions and Corrective Actions (*continued*)

Component	Alarm Condition	Action	Alarm Severity
Hardware components on the services gateway	The services gateway chassis temperature is too warm.	<ul style="list-style-type: none"> Check the room temperature. See “J-SRX240 Services Gateway Specifications” on page 7. Check the air flow. See “General Site Guidelines for Installing the J-SRX240 Services Gateway” on page 38. Check the fans. See “J-SRX240 Services Gateway Cooling System” on page 20. If you must replace a fan, contact Dell Support. See “Dell Support” on page 96. 	Amber (minor)
	The services gateway fan has failed.	<ul style="list-style-type: none"> Place your hand near the exhaust vents of the chassis to determine whether the fan is pushing air out of the chassis. Replace the failed fan. Contact Dell Support. See “Dell Support” on page 96. 	Red (major)

- Related Topics**
- Monitoring the J-SRX240 Services Gateway Chassis Using the CLI on page 87
 - Monitoring the J-SRX240 Services Gateway Components Using LEDs on page 89
 - Monitoring the J-SRX240 Services Gateway Power System on page 93
 - Dell Support on page 96
 - J-SRX240 Services Gateway Specifications on page 7
 - Clearance Requirements for Airflow and Hardware Maintenance on the J-SRX240 Services Gateway on page 40
 - J-SRX240 Services Gateway Cooling System on page 20

Monitoring the J-SRX240 Services Gateway Power System

The LEDs on the services gateway enable you to determine the performance and operation. The Power LED, located on the front panel of the services gateway, indicates the different settings with respect to the power system.

Table 35 on page 93 describes different Power LED status settings and their corrective actions.

Table 35: Services Gateway Power LED Status

LED Status	Meaning	Possible Cause and Corrective Action
Green	The device is receiving power, and the internal power supply is functional.	Normal indication. No action is required.
Amber	The Power button has been pressed and quickly released. The device is shutting down or starting up.	Normal indication. No action is required.

Table 35: Services Gateway Power LED Status (*continued*)

LED Status	Meaning	Possible Cause and Corrective Action
Off	The device is not receiving power.	<ul style="list-style-type: none"> • Verify that the AC power cord from the power source to the device is not damaged. If the insulation is cracked or broken, immediately replace the cord or cable. • Ensure that the socket you plug in is in working condition. • Ensure the device has an AC input voltage between 110 and 240 VAC. • If you cannot determine the cause of the problem or need additional assistance, contact Dell Support. See "Dell Support" on page 96.

- Related Topics**
- Monitoring the J-SRX240 Services Gateway Chassis Using the CLI on page 87
 - Monitoring the J-SRX240 Services Gateway Components Using LEDs on page 89
 - Monitoring the J-SRX240 Services Gateway Using Chassis Alarm Conditions on page 92
 - Dell Support on page 96

Resetting the Configuration File When the J-SRX240 Services Gateway Is Inaccessible

You can use the J-SRX240 Services Gateway's Reset Config button to restore the device's configuration file when the current one is faulty or fails. You can also change the default behavior of the Reset Config button.

This topic includes the following sections:

- Using the Reset Config Button on the J-SRX240 Services Gateway on page 94
- Changing the Reset Config Button Behavior on the J-SRX240 Services Gateway on page 95

Using the Reset Config Button on the J-SRX240 Services Gateway

If a configuration fails or denies management access to the services gateway, you can use the Reset Config button to restore the device to the factory default configuration or a rescue configuration. For example, if someone inadvertently commits a configuration that denies management access to a services gateway, you can delete the invalid configuration and replace it with a rescue configuration by pressing the Reset Config button.



NOTE: The Reset Config button is recessed to prevent it from being pressed accidentally.

The rescue configuration is a previously committed, valid configuration. You must have previously set the rescue configuration through the J-Web interface or the CLI.

To press the Reset Config button, insert a small probe (such as a straightened paper clip) into the pinhole on the front panel.

- By default, pressing and quickly releasing the Reset Config button loads and commits the rescue configuration through the J-Web interface or the CLI. The Status LED glows amber during this time. For details, see the *JUNOS Software CLI User Guide*.
- By default, pressing and holding the Reset Config button for 15 seconds or more—until the Status LED glows amber—deletes all configurations on the device, including the backup configurations and rescue configuration, and loads and commits the factory configuration. For details about factory default settings, see the *JUNOS Software Administration Guide*.

- Related Topics**
- Changing the Reset Config Button Behavior on the J-SRX240 Services Gateway on page 95
 - Monitoring the J-SRX240 Services Gateway Chassis Using the CLI on page 87
 - Monitoring the J-SRX240 Services Gateway Components Using LEDs on page 89
 - J-SRX240 Services Gateway LEDs on page 14

Changing the Reset Config Button Behavior on the J-SRX240 Services Gateway

You can change the default operation of the Reset Config button by limiting how the button resets the services gateway:

- To prevent the Reset Config button from setting the device to the factory default configuration and deleting all other configurations, enter the following command:

```
user@host# set chassis config-button no-clear
```

You can still press and quickly release the button to reset it to the rescue configuration.

- To prevent the Reset Config button from setting the device to the rescue configuration, enter the following command:

```
user@host# set chassis config-button no-rescue
```

You can still press and hold the button for 15 seconds or more to reset the gateway to the factory defaults.

- To disable the button and prevent the device from resetting to either configuration, use the following command:

```
user@host# set chassis config-button no-clear no-rescue
```

The **no-rescue** option prevents the Reset Config button from loading the rescue configuration. The **no-clear** option prevents the Reset Config button from deleting all configurations on the services gateway.

To return the function of the Reset Config button to its default behavior, remove the **config-button** statement from the device configuration.

- Related Topics**
- Monitoring the J-SRX240 Services Gateway Chassis Using the CLI on page 87

- Monitoring the J-SRX240 Services Gateway Components Using LEDs on page 89
- J-SRX240 Services Gateway LEDs on page 14
- Using the Reset Config Button on the J-SRX240 Services Gateway on page 94

Dell Support

If you need assistance while troubleshooting a services gateway, please go to the Dell Support website at <http://www.support.dell.com>.

PART 4

Appendixes

- Safety and Regulatory Compliance Information on page 99
- J-SRX240 Services Gateway Power Guidelines, Requirements, and Specifications on page 123
- J-SRX240 Services Gateway Interface Cable Specifications and Connector Pinouts on page 127
- Getting Help on page 131

APPENDIX A

Safety and Regulatory Compliance Information

This appendix includes the following topics:

- J-SRX240 Services Gateway Definition of Safety Warning Levels on page 99
- J-SRX240 Services Gateway General Safety Guidelines and Warnings on page 101
- J-SRX240 Services Gateway Fire Safety Requirements on page 105
- J-SRX240 Services Gateway Installation Safety Guidelines and Warnings on page 106
- J-SRX240 Services Gateway Laser and LED Safety Guidelines and Warnings on page 110
- J-SRX240 Services Gateway Maintenance and Operational Safety Guidelines and Warnings on page 113
- J-SRX240 Services Gateway Electrical Safety Guidelines and Warnings on page 118
- J-SRX240 Services Gateway Agency Approvals on page 119
- J-SRX240 Services Gateway Compliance Statements for EMC Requirements on page 120
- J-SRX240 Services Gateway Compliance Statements for Environmental Requirements on page 121
- J-SRX240 Services Gateway Compliance Statements for Acoustic Noise on page 122

J-SRX240 Services Gateway Definition of Safety Warning Levels

This topic defines the following three levels of safety warnings used in Dell technical publications:



NOTE: You might find this information helpful in a particular situation or might otherwise overlook it.



CAUTION: You need to observe the specified guidelines to avoid minor injury or discomfort to you or severe damage to the services gateway.



WARNING: This symbol means danger. You are in a situation that could cause bodily injury. Before you work on any equipment, be aware of the hazards involved with electrical circuitry and be familiar with standard practices for preventing accidents.

Waarschuwing Dit waarschuwingssymbool betekent gevaar. U verkeert in een situatie die lichamelijk letsel kan veroorzaken. Voordat u aan enige apparatuur gaat werken, dient u zich bewust te zijn van de bij elektrische schakelingen betrokken risico's en dient u op de hoogte te zijn van standaard maatregelen om ongelukken te voorkomen.

Varoitus Tämä varoitusmerkki merkitsee vaaraa. Olet tilanteessa, joka voi johtaa ruumiinvammaan. Ennen kuin työskentelet minkään laitteiston parissa, ota selvää sähkökytkentöihin liittyvistä vaaroista ja tavanomaisista onnettomuuksien ehkäisykeinoista.

Attention Ce symbole d'avertissement indique un danger. Vous vous trouvez dans une situation pouvant causer des blessures ou des dommages corporels. Avant de travailler sur un équipement, soyez conscient des dangers posés par les circuits électriques et familiarisez-vous avec les procédures couramment utilisées pour éviter les accidents.

Warnung Dieses Warnsymbol bedeutet Gefahr. Sie befinden sich in einer Situation, die zu einer Körperverletzung führen könnte. Bevor Sie mit der Arbeit an irgendeinem Gerät beginnen, seien Sie sich der mit elektrischen Stromkreisen verbundenen Gefahren und der Standardpraktiken zur Vermeidung von Unfällen bewusst.

Avvertenza Questo simbolo di avvertenza indica un pericolo. La situazione potrebbe causare infortuni alle persone. Prima di lavorare su qualsiasi apparecchiatura, occorre conoscere i pericoli relativi ai circuiti elettrici ed essere al corrente delle pratiche standard per la prevenzione di incidenti.

Advarsel Dette varselsymbolet betyr fare. Du befinner deg i en situasjon som kan føre til personskade. Før du utfører arbeid på utstyr, må du være oppmerksom på de faremomentene som elektriske kretser innebærer, samt gjøre deg kjent med vanlig praksis når det gjelder å unngå ulykker.

Aviso Este símbolo de aviso indica perigo. Encontra-se numa situação que lhe poderá causar danos físicos. Antes de começar a trabalhar com qualquer equipamento, familiarize-se com os perigos relacionados com circuitos eléctricos, e com quaisquer práticas comuns que possam prevenir possíveis acidentes.

¡Atención! Este símbolo de aviso significa peligro. Existe riesgo para su integridad física. Antes de manipular cualquier equipo, considerar los riesgos que entraña la corriente eléctrica y familiarizarse con los procedimientos estándar de prevención de accidentes.

Varning! Denna varningssymbol signalerar fara. Du befinner dig i en situation som kan leda till personskada. Innan du utför arbete på någon utrustning måste du vara medveten om farorna med elkretsar och känna till vanligt förfarande för att förebygga skador.

-
- Related Topics**
- J-SRX240 Services Gateway General Safety Guidelines and Warnings on page 101
 - J-SRX240 Services Gateway Fire Safety Requirements on page 105

- J-SRX240 Services Gateway Installation Safety Guidelines and Warnings on page 106
- J-SRX240 Services Gateway Laser and LED Safety Guidelines and Warnings on page 110
- J-SRX240 Services Gateway Maintenance and Operational Safety Guidelines and Warnings on page 113
- J-SRX240 Services Gateway Electrical Safety Guidelines and Warnings on page 118

J-SRX240 Services Gateway General Safety Guidelines and Warnings

General Safety Guidelines and Warnings

The following guidelines help ensure your safety and protect the services gateway from damage. The list of guidelines might not address all potentially hazardous situations in your working environment, so be alert and exercise good judgment at all times.

- Perform only the procedures explicitly described in these topics. Make sure that only authorized service personnel perform other system services.
- Keep the area around the chassis clear and free from dust before, during, and after installation.
- Keep tools away from areas where people could trip on them.
- Wear safety glasses if you are working under any conditions that could be hazardous to your eyes.
- Do not perform any actions that create a potential hazard to people or make the equipment unsafe.
- Never install or manipulate wiring during electrical storms.
- Never install electrical jacks in wet locations unless the jacks are specifically designed for wet environments.
- Do not open or remove chassis covers or sheet metal parts unless instructions are provided in this guide. Such an action could cause severe electrical shock.
- Do not push or force any objects through any opening in the chassis frame. Such an action could result in electrical shock or fire.
- Avoid spilling liquid onto the services gateway chassis or onto any services gateway component. Such an action could cause electrical shock or damage the services gateway.
- Avoid touching uninsulated electrical wires or terminals that have not been disconnected from their power source. Such an action could cause electrical shock.

Qualified Personnel Warning



WARNING: Only trained and qualified personnel should install or replace the services gateway.

Waarschuwing Installatie en reparaties mogen uitsluitend door getraind en bevoegd personeel uitgevoerd worden.

Varoitus Ainoastaan koulutettu ja pätevä henkilökunta saa asentaa tai vaihtaa tämän laitteen.

Attention Tout installation ou remplacement de l'appareil doit être réalisé par du personnel qualifié et compétent.

Warnung Gerät nur von geschultem, qualifiziertem Personal installieren oder auswechseln lassen.

Avvertenza Solo personale addestrato e qualificato deve essere autorizzato ad installare o sostituire questo apparecchio.

Advarsel Kun kvalifisert personell med riktig opplæring bør montere eller bytte ut dette utstyret.

Aviso Este equipamento deverá ser instalado ou substituído apenas por pessoal devidamente treinado e qualificado.

¡Atención! Estos equipos deben ser instalados y reemplazados exclusivamente por personal técnico adecuadamente preparado y capacitado.

Warning! Denna utrustning ska endast installeras och bytas ut av utbildad och kvalificerad personal.

Restricted Access Area Warning



WARNING: The services gateway is intended for installation in restricted access areas. A restricted access area is an area to which access can be gained only by service personnel through the use of a special tool, lock and key, or other means of security, and which is controlled by the authority responsible for the location.

Waarschuwing Dit toestel is bedoeld voor installatie op plaatsen met beperkte toegang. Een plaats met beperkte toegang is een plaats waar toegang slechts door servicepersoneel verkregen kan worden door middel van een speciaal instrument, een slot en sleutel, of een ander veiligheidsmiddel, en welke beheerd wordt door de overheidsinstantie die verantwoordelijk is voor de locatie.

Varoitus Tämä laite on tarkoitettu asennettavaksi paikkaan, johon pääsy on rajoitettua. Paikka, johon pääsy on rajoitettua, tarkoittaa paikkaa, johon vain huoltohenkilöstö pääsee jonkin erikoistyökalun, lukkoon sopivan avaimen tai jonkin muun turvalaitteen avulla ja joka on paikasta vastuussa olevien toimivaltaisten henkilöiden valvoma.

Attention Cet appareil est à installer dans des zones d'accès réservé. Ces dernières sont des zones auxquelles seul le personnel de service peut accéder en utilisant un outil spécial, un mécanisme de verrouillage et une clé, ou tout autre moyen de sécurité.

L'accès aux zones de sécurité est sous le contrôle de l'autorité responsable de l'emplacement.

Warnung Diese Einheit ist zur Installation in Bereichen mit beschränktem Zutritt vorgesehen. Ein Bereich mit beschränktem Zutritt ist ein Bereich, zu dem nur Wartungspersonal mit einem Spezialwerkzeugs, Schloß und Schlüssel oder anderer Sicherheitsvorkehrungen Zugang hat, und der von dem für die Anlage zuständigen Gremium kontrolliert wird.

Avvertenza Questa unità deve essere installata in un'area ad accesso limitato. Un'area ad accesso limitato è un'area accessibile solo a personale di assistenza tramite un'attrezzo speciale, lucchetto, o altri dispositivi di sicurezza, ed è controllata dall'autorità responsabile della zona.

Advarsel Denne enheten er laget for installasjon i områder med begrenset adgang. Et område med begrenset adgang gir kun adgang til servicepersonale som bruker et spesielt verktøy, lås og nøkkel, eller en annen sikkerhetsanordning, og det kontrolleres av den autoriteten som er ansvarlig for området.

Aviso Esta unidade foi concebida para instalação em áreas de acesso restrito. Uma área de acesso restrito é uma área à qual apenas tem acesso o pessoal de serviço autorizado, que possua uma ferramenta, chave e fechadura especial, ou qualquer outra forma de segurança. Esta área é controlada pela autoridade responsável pelo local.

¡Atención! Esta unidad ha sido diseñada para instalarse en áreas de acceso restringido. Área de acceso restringido significa un área a la que solamente tiene acceso el personal de servicio mediante la utilización de una herramienta especial, cerradura con llave, o algún otro medio de seguridad, y que está bajo el control de la autoridad responsable del local.

Varning! Denna enhet är avsedd för installation i områden med begränsat tillträde. Ett område med begränsat tillträde får endast tillträdas av servicepersonal med ett speciellt verktyg, lås och nyckel, eller annan säkerhetsanordning, och kontrolleras av den auktoritet som ansvarar för området.

Preventing Electrostatic Discharge Damage to the Services Gateway

Many services gateway hardware components are sensitive to damage from static electricity. Some components can be impaired by voltages as low as 30 V. You can easily generate potentially damaging static voltages whenever you handle plastic or foam packing material or if you move components across plastic or carpets. Observe the following guidelines to minimize the potential for electrostatic discharge (ESD) damage, which can cause intermittent or complete component failures:

- Always use an ESD wrist strap or ankle strap, and verify that it is in direct contact with your skin.



CAUTION: For safety, periodically check the resistance value of the ESD strap. The measurement should be in the range of 1 to 10 Mohms.

- When handling any component that is removed from the chassis, verify that the equipment end of your ESD strap is attached to one of the ESD points on the chassis.
- Avoid contact between the component and your clothing. ESD voltages emitted from clothing can still damage components.
- When removing or installing a component, always place it component-side up on an antistatic surface, in an antistatic card rack, or in an electrostatic bag. If you are returning a component, place it into an electrostatic bag before packing it. See Figure 15 on page 104.

Figure 15: Placing a Component into an Electrostatic Bag

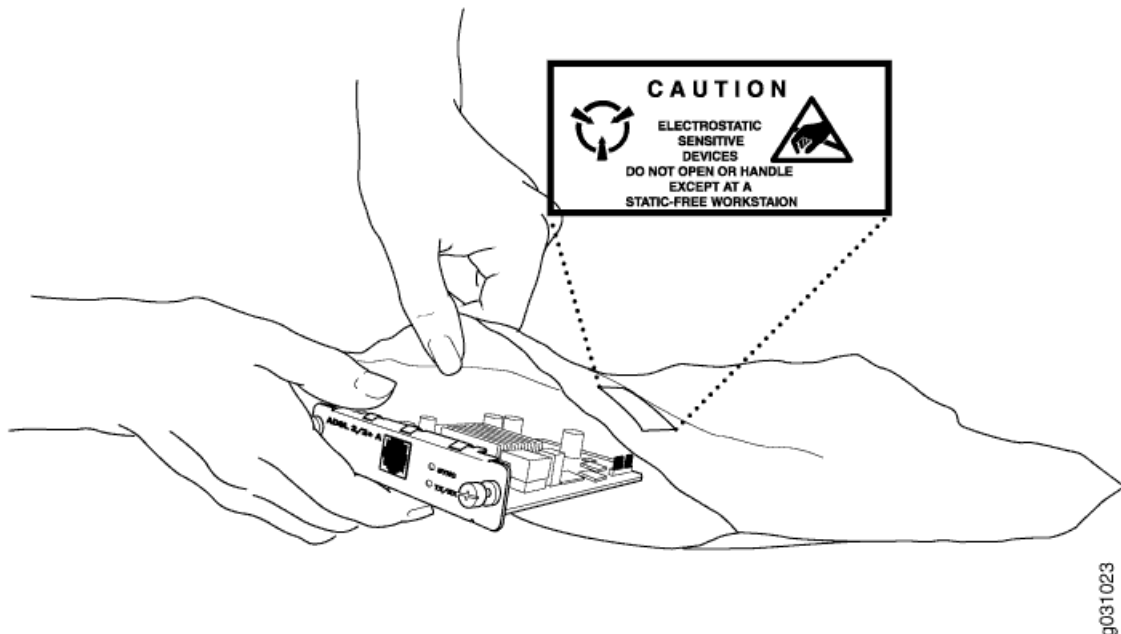

g031023

- Related Topics**
- J-SRX240 Services Gateway Definition of Safety Warning Levels on page 99
 - J-SRX240 Services Gateway Fire Safety Requirements on page 105
 - J-SRX240 Services Gateway Installation Safety Guidelines and Warnings on page 106

- J-SRX240 Services Gateway Laser and LED Safety Guidelines and Warnings on page 110
- J-SRX240 Services Gateway Maintenance and Operational Safety Guidelines and Warnings on page 113
- J-SRX240 Services Gateway Electrical Safety Guidelines and Warnings on page 118

J-SRX240 Services Gateway Fire Safety Requirements

Services Gateway Fire Suppression Procedure and Equipment

In the event of a fire emergency involving devices and other network equipment, the safety of people is the primary concern. Establish procedures for protecting people in the event of a fire emergency, provide safety training, and properly provision fire-control equipment and fire extinguishers.

In addition, establish procedures to protect your equipment in the event of a fire emergency. Dell products should be installed in an environment suitable for electronic equipment. We recommend that fire suppression equipment be available in the event of a fire in the vicinity of the equipment and that all local fire, safety, and electrical codes and ordinances be observed when installing and operating your equipment.

In the event of an electrical hazard or an electrical fire, first turn power off to the equipment at the source. Then use a Type C fire extinguisher to extinguish the fire. Type C fire extinguishers, which use noncorrosive fire retardants such as carbon dioxide (CO₂) and Halotron™, are most effective for suppressing electrical fires. Type C fire extinguishers displace the oxygen from the point of combustion to eliminate the fire. For extinguishing fire on or around equipment that draws air from the environment for cooling, use this type of inert oxygen displacement extinguisher instead of an extinguisher that leave residues on equipment.

Do not use multipurpose Type ABC chemical fire extinguishers (dry chemical fire extinguishers) near Dell equipment. The primary ingredient in these fire extinguishers is monoammonium phosphate, which is very sticky and difficult to clean. In addition, in minute amounts of moisture, monoammonium phosphate can become highly corrosive and corrodes most metals.

Any equipment in a room in which a chemical fire extinguisher has been discharged is subject to premature failure and unreliable operation. The equipment is considered to be irreparably damaged.



NOTE: To keep warranties effective, do not use a dry chemical fire extinguisher to control a fire at or near a J-SRX Series services gateway. If a dry chemical fire extinguisher is used, the unit is no longer eligible for coverage under a service agreement.

We recommend that you dispose of any irreparably damaged equipment in an environmentally responsible manner.

- Related Topics**
- J-SRX240 Services Gateway Definition of Safety Warning Levels on page 99

- J-SRX240 Services Gateway General Safety Guidelines and Warnings on page 101
- J-SRX240 Services Gateway Installation Safety Guidelines and Warnings on page 106
- J-SRX240 Services Gateway Laser and LED Safety Guidelines and Warnings on page 110
- J-SRX240 Services Gateway Maintenance and Operational Safety Guidelines and Warnings on page 113
- J-SRX240 Services Gateway Electrical Safety Guidelines and Warnings on page 118

J-SRX240 Services Gateway Installation Safety Guidelines and Warnings

Installation Instructions Warning



WARNING: Read the installation instructions before you connect the services gateway to a power source.

Waarschuwing Raadpleeg de installatie-aanwijzingen voordat u het systeem met de voeding verbindt.

Varoitus Lue asennusohjeet ennen järjestelmän yhdistämistä virtalähteeseen.

Attention Avant de brancher le système sur la source d'alimentation, consulter les directives d'installation.

Warnung Lesen Sie die Installationsanweisungen, bevor Sie das System an die Stromquelle anschließen.

Avvertenza Consultare le istruzioni di installazione prima di collegare il sistema all'alimentatore.

Advarsel Les installasjonsinstruksjonene før systemet kobles til strømkilden.

Aviso Leia as instruções de instalação antes de ligar o sistema à sua fonte de energia.

¡Atención! Ver las instrucciones de instalación antes de conectar el sistema a la red de alimentación.

Varning! Läs installationsanvisningarna innan du kopplar systemet till dess strömförsörjningsenhet.

Rack-Mounting Requirements and Warnings

Ensure that the equipment rack into which the services gateway is installed is evenly and securely supported to avoid the hazardous condition that could result from uneven mechanical loading.



WARNING: To prevent bodily injury when mounting or servicing the services gateway in a rack, take the following precautions to ensure that the system remains stable. The following directives help maintain your safety:

- The services gateway must be installed into a rack that is secured to the building structure.
- The services gateway should be mounted at the bottom of the rack if it is the only unit in the rack.
- When mounting the services gateway in a partially filled rack, load the rack from the bottom to the top with the heaviest component at the bottom of the rack.
- If the rack is provided with stabilizing devices, install the stabilizers before mounting or servicing the services gateway in the rack.

Waarschuwing Om lichamelijk letsel te voorkomen wanneer u dit toestel in een rek monteert of het daar een servicebeurt geeft, moet u speciale voorzorgsmaatregelen nemen om ervoor te zorgen dat het toestel stabiel blijft. De onderstaande richtlijnen worden verstrekt om uw veiligheid te verzekeren:

- De J-SRX Series services gateway moet in een stellage worden geïnstalleerd die aan een bouwsel is verankerd.
- Dit toestel dient onderaan in het rek gemonteerd te worden als het toestel het enige in het rek is.
- Wanneer u dit toestel in een gedeeltelijk gevuld rek monteert, dient u het rek van onderen naar boven te laden met het zwaarste onderdeel onderaan in het rek.
- Als het rek voorzien is van stabiliseringshulpmiddelen, dient u de stabilisatoren te monteren voordat u het toestel in het rek monteert of het daar een servicebeurt geeft.

Varoitus Kun laite asetetaan telineeseen tai huolletaan sen ollessa telineessä, on noudatettava erityisiä varoimia järjestelmän vakavuuden säilyttämiseksi, jotta vältetään loukkaantumiselta. Noudata seuraavia turvallisuusohjeita:

- J-SRX Series services gateway on asennettava telineeseen, joka on kiinnitetty rakennukseen.
- Jos telineessä ei ole muita laitteita, aseta laite telineen alaosaan.
- Jos laite asetetaan osaksi täytettyyn telineeseen, aloita kuormittaminen sen alaosasta kaikkein raskaimmalla esineellä ja siirry sitten sen yläosaan.
- Jos telinettä varten on vakaimet, asenna ne ennen laitteen asettamista telineeseen tai sen huoltamista siinä.

Attention Pour éviter toute blessure corporelle pendant les opérations de montage ou de réparation de cette unité en casier, il convient de prendre des précautions spéciales afin de maintenir la stabilité du système. Les directives ci-dessous sont destinées à assurer la protection du personnel:

- Le rack sur lequel est monté le J-SRX Series services gateway doit être fixé à la structure du bâtiment.
- Si cette unité constitue la seule unité montée en casier, elle doit être placée dans le bas.
- Si cette unité est montée dans un casier partiellement rempli, charger le casier de bas en haut en plaçant l'élément le plus lourd dans le bas.
- Si le casier est équipé de dispositifs stabilisateurs, installer les stabilisateurs avant de monter ou de réparer l'unité en casier.

Warnung Zur Vermeidung von Körperverletzung beim Anbringen oder Warten dieser Einheit in einem Gestell müssen Sie besondere Vorkehrungen treffen, um sicherzustellen, daß das System stabil bleibt. Die folgenden Richtlinien sollen zur Gewährleistung Ihrer Sicherheit dienen:

- Der J-SRX Series services gateway muß in einem Gestell installiert werden, das in der Gebäudestruktur verankert ist.
- Wenn diese Einheit die einzige im Gestell ist, sollte sie unten im Gestell angebracht werden.
- Bei Anbringung dieser Einheit in einem zum Teil gefüllten Gestell ist das Gestell von unten nach oben zu laden, wobei das schwerste Bauteil unten im Gestell anzubringen ist.
- Wird das Gestell mit Stabilisierungszubehör geliefert, sind zuerst die Stabilisatoren zu installieren, bevor Sie die Einheit im Gestell anbringen oder sie warten.

Avvertenza Per evitare infortuni fisici durante il montaggio o la manutenzione di questa unità in un supporto, occorre osservare speciali precauzioni per garantire che il sistema rimanga stabile. Le seguenti direttive vengono fornite per garantire la sicurezza personale:

- Il J-SRX Series services gateway deve essere installato in un telaio, il quale deve essere fissato alla struttura dell'edificio.
- Questa unità deve venire montata sul fondo del supporto, se si tratta dell'unica unità da montare nel supporto.
- Quando questa unità viene montata in un supporto parzialmente pieno, caricare il supporto dal basso all'alto, con il componente più pesante sistemato sul fondo del supporto.
- Se il supporto è dotato di dispositivi stabilizzanti, installare tali dispositivi prima di montare o di procedere alla manutenzione dell'unità nel supporto.

Advarsel Unngå fysiske skader under montering eller reparasjonsarbeid på denne enheten når den befinner seg i et kabinett. Vær nøye med at systemet er stabilt. Følgende retningslinjer er gitt for å verne om sikkerheten:

- J-SRX Series services gateway må installeres i et stativ som er forankret til bygningsstrukturen.
- Denne enheten bør monteres nederst i kabinettet hvis dette er den eneste enheten i kabinettet.
- Ved montering av denne enheten i et kabinett som er delvis fylt, skal kabinettet lastes fra bunnen og opp med den tyngste komponenten nederst i kabinettet.
- Hvis kabinettet er utstyrt med stabiliseringsutstyr, skal stabilisatorene installeres før montering eller utføring av reparasjonsarbeid på enheten i kabinettet.

Aviso Para se prevenir contra danos corporais ao montar ou reparar esta unidade numa estante, deverá tomar precauções especiais para se certificar de que o sistema possui um suporte estável. As seguintes directrizes ajudá-lo-ão a efectuar o seu trabalho com segurança:

- O J-SRX Series services gateway deverá ser instalado numa prateleira fixa à estrutura do edifício.
- Esta unidade deverá ser montada na parte inferior da estante, caso seja esta a única unidade a ser montada.
- Ao montar esta unidade numa estante parcialmente ocupada, coloque os itens mais pesados na parte inferior da estante, arrumando-os de baixo para cima.
- Se a estante possuir um dispositivo de estabilização, instale-o antes de montar ou reparar a unidade.

¡Atención! Para evitar lesiones durante el montaje de este equipo sobre un bastidor, o posteriormente durante su mantenimiento, se debe poner mucho cuidado en que el sistema quede bien estable. Para garantizar su seguridad, proceda según las siguientes instrucciones:

- El J-SRX Series services gateway debe instalarse en un bastidor fijado a la estructura del edificio.
- Colocar el equipo en la parte inferior del bastidor, cuando sea la única unidad en el mismo.
- Cuando este equipo se vaya a instalar en un bastidor parcialmente ocupado, comenzar la instalación desde la parte inferior hacia la superior colocando el equipo más pesado en la parte inferior.
- Si el bastidor dispone de dispositivos estabilizadores, instalar éstos antes de montar o proceder al mantenimiento del equipo instalado en el bastidor.

Varning! För att undvika kroppsskada när du installerar eller utför underhållsarbete på denna enhet på en ställning måste du vidta särskilda försiktighetsåtgärder för att försäkra dig om att systemet står stadigt. Följande riktlinjer ges för att trygga din säkerhet:

- J-SRX Series services gateway måste installeras i en ställning som är förankrad i byggnadens struktur.
- Om denna enhet är den enda enheten på ställningen skall den installeras längst ned på ställningen.
- Om denna enhet installeras på en delvis fylld ställning skall ställningen fyllas nedifrån och upp, med de tyngsta enheterna längst ned på ställningen.
- Om ställningen är försedd med stabiliseringsdon skall dessa monteras fast innan enheten installeras eller underhålls på ställningen.

Related Topics

- J-SRX240 Services Gateway Definition of Safety Warning Levels on page 99
- J-SRX240 Services Gateway General Safety Guidelines and Warnings on page 101
- J-SRX240 Services Gateway Fire Safety Requirements on page 105
- J-SRX240 Services Gateway Laser and LED Safety Guidelines and Warnings on page 110
- J-SRX240 Services Gateway Maintenance and Operational Safety Guidelines and Warnings on page 113
- J-SRX240 Services Gateway Electrical Safety Guidelines and Warnings on page 118

J-SRX240 Services Gateway Laser and LED Safety Guidelines and Warnings

The 1-Port SFP Mini-Physical Interface Module (Mini-PIM) is equipped with laser transmitters, which are considered a Class 1 Laser Product by the USA Food and Drug Administration, and they are evaluated as a Class 1 Laser Product per EN 60825–1 +A11 +A2 requirements.

This topic includes the following section:

- Laser and LED Safety Guidelines and Warnings on page 110

Laser and LED Safety Guidelines and Warnings

General Laser Safety Guidelines

When working around Mini-PIMs, observe the following safety guidelines to prevent eye injury:

- Do not look into unterminated ports or at fibers that connect to unknown sources.
- Do not examine unterminated optical ports with optical instruments.
- Avoid direct exposure to the beam.



WARNING: Unterminated optical connectors can emit invisible laser radiation. The lens in the human eye focuses all the laser power on the retina, so focusing the eye directly on a laser source—even a low-power laser—could permanently damage the eye.

Class 1 Laser Product Warning



WARNING: Class 1 laser product.
Waarschuwing Klasse-1 laser produkt.
Varoitus Luokan 1 lasertuote.
Attention Produit laser de classe I.
Warnung Laserprodukt der Klasse 1.
Avvertenza Prodotto laser di Classe 1.
Advarsel Laserprodukt av klasse 1.
Aviso Produto laser de classe 1.
¡Atención! Producto láser Clase I.
Varning! Laserprodukt av klass 1.

Class 1 LED Product Warning



WARNING: Class 1 LED product.
Waarschuwing Klasse 1 LED-product.
Varoitus Luokan 1 valodiodituote.
Attention Alarme de produit LED Class I.
Warnung Class 1 LED-Produktwarnung.
Avvertenza Avvertenza prodotto LED di Classe 1.
Advarsel LED-produkt i klasse 1.
Aviso Produto de classe 1 com LED.
¡Atención! Aviso sobre producto LED de Clase 1.
Varning! Lysdiodprodukt av klass 1.

Laser Beam Warning



WARNING: Do not stare into the laser beam or view it directly with optical instruments.
Waarschuwing Niet in de straal staren of hem rechtstreeks bekijken met optische instrumenten.

Varoitus Älä katso säteeseen äläkä tarkastele sitä suoraan optisen laitteen avulla.

Attention Ne pas fixer le faisceau des yeux, ni l'observer directement à l'aide d'instruments optiques.

Warnung Nicht direkt in den Strahl blicken und ihn nicht direkt mit optischen Geräten prüfen.

Avvertenza Non fissare il raggio con gli occhi né usare strumenti ottici per osservarlo direttamente.

Advarsel Stirr eller se ikke direkte p strlen med optiske instrumenter.

Aviso Não olhe fixamente para o raio, nem olhe para ele directamente com instrumentos ópticos.

iAtención! No mirar fijamente el haz ni observarlo directamente con instrumentos ópticos.

Warning! Rikta inte blicken in mot strålen och titta inte direkt på den genom optiska instrument.

Radiation from Open Port Apertures Warning



WARNING: Because invisible radiation may be emitted from the aperture of the port when no fiber cable is connected, avoid exposure to radiation and do not stare into open apertures.

Waarschuwing Aangezien onzichtbare straling vanuit de opening van de poort kan komen als er geen fiberkabel aangesloten is, dient blootstelling aan straling en het kijken in open openingen vermeden te worden.

Varoitus Koska portin aukosta voi emittoitua näkymätöntä säteilyä, kun kuitukaapelia ei ole kytkettyä, vältä säteilylle altistumista äläkä katso avoimiin aukkoihin.

Attention Des radiations invisibles à l'il nu pouvant traverser l'ouverture du port lorsqu'aucun câble en fibre optique n'y est connecté, il est recommandé de ne pas regarder fixement l'intérieur de ces ouvertures.

Warnung Aus der Port-Öffnung können unsichtbare Strahlen emittieren, wenn kein Glasfaserkabel angeschlossen ist. Vermeiden Sie es, sich den Strahlungen auszusetzen, und starren Sie nicht in die Öffnungen!

Avvertenza Quando i cavi in fibra non sono inseriti, radiazioni invisibili possono essere emesse attraverso l'apertura della porta. Evitate di esporvi alle radiazioni e non guardate direttamente nelle aperture.

Advarsel Unngå utsettelse for stråling, og stirr ikke inn i åpninger som er åpne, fordi usynlig stråling kan emitteres fra portens åpning når det ikke er tilkoblet en fiberkabel.

Aviso Dada a possibilidade de emissão de radiação invisível através do orifício da via de acesso, quando esta não tiver nenhum cabo de fibra conectado, deverá evitar a exposição à radiação e não deverá olhar fixamente para orifícios que se encontrarem a descoberto.

¡Atención! Debido a que la apertura del puerto puede emitir radiación invisible cuando no existe un cable de fibra conectado, evite mirar directamente a las aperturas para no exponerse a la radiación.

Varning! Osynlig strålning kan avges från en portöppning utan ansluten fiberkabel och du bör därför undvika att bli utsatt för strålning genom att inte stirra in i oskyddade öppningar.

- Related Topics**
- J-SRX240 Services Gateway Definition of Safety Warning Levels on page 99
 - J-SRX240 Services Gateway General Safety Guidelines and Warnings on page 101
 - J-SRX240 Services Gateway Fire Safety Requirements on page 105
 - J-SRX240 Services Gateway Installation Safety Guidelines and Warnings on page 106
 - J-SRX240 Services Gateway Maintenance and Operational Safety Guidelines and Warnings on page 113
 - J-SRX240 Services Gateway Electrical Safety Guidelines and Warnings on page 118

J-SRX240 Services Gateway Maintenance and Operational Safety Guidelines and Warnings

This topic includes the following sections:

- Safety Guidelines and Warnings on page 113

Safety Guidelines and Warnings

Battery Handling Warning



WARNING: Replacing the battery incorrectly might result in an explosion. Replace the battery only with the same or equivalent type recommended by the manufacturer. Dispose of used batteries according to the manufacturer's instructions.

Waarschuwing Er is ontploffingsgevaar als de batterij verkeerd vervangen wordt. Vervang de batterij slechts met hetzelfde of een equivalent type dat door de fabrikant aanbevolen is. Gebruikte batterijen dienen overeenkomstig fabrieksvoorschriften weggegooid te worden.

Varoitus Räjähdyksen vaara, jos akku on vaihdettu väärään akkuun. Käytä vaihtamiseen ainoastaan saman- tai vastaavantyyppistä akkua, joka on valmistajan suosittama. Hävitä käytetyt akut valmistajan ohjeiden mukaan.

Attention Danger d'explosion si la pile n'est pas remplacée correctement. Ne la remplacer que par une pile de type semblable ou équivalent, recommandée par le fabricant. Jeter les piles usagées conformément aux instructions du fabricant.

Warnung Bei Einsetzen einer falschen Batterie besteht Explosionsgefahr. Ersetzen Sie die Batterie nur durch den gleichen oder vom Hersteller empfohlenen Batterietyp. Entsorgen Sie die benutzten Batterien nach den Anweisungen des Herstellers.

Avvertenza Pericolo di esplosione se la batteria non è installata correttamente. Sostituire solo con una di tipo uguale o equivalente, consigliata dal produttore. Eliminare le batterie usate secondo le istruzioni del produttore.

Advarsel Det kan være fare for eksplosjon hvis batteriet skiftes på feil måte. Skift kun med samme eller tilsvarende type som er anbefalt av produsenten. Kasser brukte batterier i henhold til produsentens instruksjoner.

Aviso Existe perigo de explosão se a bateria for substituída incorrectamente. Substitua a bateria por uma bateria igual ou de um tipo equivalente recomendado pelo fabricante. Destrua as baterias usadas conforme as instruções do fabricante.

¡Atención! Existe peligro de explosión si la batería se reemplaza de manera incorrecta. Reemplazar la batería exclusivamente con el mismo tipo o el equivalente recomendado por el fabricante. Desechar las baterías gastadas según las instrucciones del fabricante.

Warning! Explosionsfara vid felaktigt batteribyte. Ersätt endast batteriet med samma batterityp som rekommenderas av tillverkaren eller motsvarande. Följ tillverkarens anvisningar vid kassering av använda batterier.

Jewelry Removal Warning



WARNING: Before working on equipment that is connected to power lines, remove jewelry, including rings, necklaces, and watches. Metal objects heat up when connected to power and ground and can cause serious burns or weld the metal object to the terminals.

Waarschuwing Alvorens aan apparatuur te werken die met elektrische leidingen is verbonden, sieraden (inclusief ringen, kettingen en horloges) verwijderen. Metalen voorwerpen worden warm wanneer ze met stroom en aarde zijn verbonden, en kunnen ernstige brandwonden veroorzaken of het metalen voorwerp aan de aansluitklemmen lassen.

Varoitus Ennen kuin työskentelet voimavirtajohtoihin kytkettyjen laitteiden parissa, ota pois kaikki korut (sormukset, kaulakorut ja kellot mukaan lukien). Metalliesineet kuumenevat, kun ne ovat yhteydessä sähkövirran ja maan kanssa, ja ne voivat aiheuttaa vakavia palovammoja tai hitsata metalliesineet kiinni liitäntänapoihin.

Attention Avant d'accéder à cet équipement connecté aux lignes électriques, ôter tout bijou (anneaux, colliers et montres compris). Lorsqu'ils sont branchés à l'alimentation

et reliés à la terre, les objets métalliques chauffent, ce qui peut provoquer des blessures graves ou souder l'objet métallique aux bornes.

Warnung Vor der Arbeit an Geräten, die an das Netz angeschlossen sind, jeglichen Schmuck (einschließlich Ringe, Ketten und Uhren) abnehmen. Metallgegenstände erhitzen sich, wenn sie an das Netz und die Erde angeschlossen werden, und können schwere Verbrennungen verursachen oder an die Anschlußklemmen angeschweißt werden.

Avvertenza Prima di intervenire su apparecchiature collegate alle linee di alimentazione, togliersi qualsiasi monile (inclusi anelli, collane, braccialetti ed orologi). Gli oggetti metallici si riscaldano quando sono collegati tra punti di alimentazione e massa: possono causare ustioni gravi oppure il metallo può saldarsi ai terminali.

Advarsel Fjern alle smykker (inkludert ringer, halskjeder og klokker) før du skal arbeide på utstyr som er koblet til kraftledninger. Metallgjenstander som er koblet til kraftledninger og jord blir svært varme og kan forårsake alvorlige brannskader eller smelte fast til polene.

Aviso Antes de trabalhar em equipamento que esteja ligado a linhas de corrente, retire todas as jóias que estiver a usar (incluindo anéis, fios e relógios). Os objectos metálicos aquecerão em contacto com a corrente e em contacto com a ligação à terra, podendo causar queimaduras graves ou ficarem soldados aos terminais.

¡Atención! Antes de operar sobre equipos conectados a líneas de alimentación, quitarse las joyas (incluidos anillos, collares y relojes). Los objetos de metal se calientan cuando se conectan a la alimentación y a tierra, lo que puede ocasionar quemaduras graves o que los objetos metálicos queden soldados a los bornes.

Varning! Tag av alla smycken (inklusive ringar, halsband och armbandsur) innan du arbetar på utrustning som är kopplad till kraftledningar. Metallobjekt hettas upp när de kopplas ihop med ström och jord och kan förorsaka allvarliga brännskador; metallobjekt kan också sammansvetsas med kontakterna.

Lightning Activity Warning



WARNING: Do not work on the system or connect or disconnect cables during periods of lightning activity.

Waarschuwing Tijdens onweer dat gepaard gaat met bliksem, dient u niet aan het systeem te werken of kabels aan te sluiten of te ontkoppelen.

Varoitus Älä työskentele järjestelmän parissa äläkä yhdistä tai irrota kaapeleita ukkosilmalla.

Attention Ne pas travailler sur le système ni brancher ou débrancher les câbles pendant un orage.

Warnung Arbeiten Sie nicht am System und schließen Sie keine Kabel an bzw. trennen Sie keine ab, wenn es gewittert.

Avvertenza Non lavorare sul sistema o collegare oppure scollegare i cavi durante un temporale con fulmini.

Advarsel Utfør aldri arbeid på systemet, eller koble kabler til eller fra systemet når det tordner eller lynner.

Aviso Não trabalhe no sistema ou ligue e desligue cabos durante períodos de mau tempo (trovoada).

¡Atención! No operar el sistema ni conectar o desconectar cables durante el transcurso de descargas eléctricas en la atmósfera.

Varning! Vid åska skall du aldrig utföra arbete på systemet eller ansluta eller koppla loss kablar.

Operating Temperature Warning



WARNING: To prevent the services gateway from overheating, do not operate it in an area that exceeds the maximum recommended ambient temperature of 104°F (40°C). To prevent airflow restriction, allow at least 6 in. (15.2 cm) of clearance around the ventilation openings.

Waarschuwing Om te voorkomen dat welke services gateway van de J-SRX Series services gateway dan ook oververhit raakt, dient u deze niet te bedienen op een plaats waar de maximale aanbevolen omgevingstemperatuur van 40°C wordt overschreden. Om te voorkomen dat de luchtstroom wordt beperkt, dient er minstens 15,2 cm speling rond de ventilatie-openingen te zijn.

Varoitus Ettei J-SRX Series services gateway-sarjan reititin ylikuumentuisi, sitä ei saa käyttää tilassa, jonka lämpötila ylittää korkeimman suositellun ympäristölämpötilan 40°C. Ettei ilmanvaihto estyisi, tuuletusaukkojen ympärille on jätettävä ainakin 15,2 cm tilaa.

Attention Pour éviter toute surchauffe des routeurs de la gamme J-SRX Series services gateway, ne l'utilisez pas dans une zone où la température ambiante est supérieure à 40°C. Pour permettre un flot d'air constant, dégagez un espace d'au moins 15,2 cm autour des ouvertures de ventilations.

Warnung Um einen services gateway der services gateway vor Überhitzung zu schützen, darf dieser nicht in einer Gegend betrieben werden, in der die Umgebungstemperatur das empfohlene Maximum von 40°C überschreitet. Um Lüftungsverschluß zu verhindern, achten Sie darauf, daß mindestens 15,2 cm lichter Raum um die Lüftungsöffnungen herum frei bleibt.

Avvertenza Per evitare il surriscaldamento dei services gateway, non adoperateli in un locale che ecceda la temperatura ambientale massima di 40°C. Per evitare che la circolazione dell'aria sia impedita, lasciate uno spazio di almeno 15.2 cm di fronte alle aperture delle ventole.

Advarsel Unngå overoppheting av eventuelle rutere i J-SRX Series services gateway. Disse skal ikke brukes på steder der den anbefalte maksimale omgivelsestemperaturen overstiger 40°C (104°F). Sørg for at klaringen rundt lufteåpningene er minst 15,2 cm (6 tommer) for å forhindre nedsatt luftsirkulasjon.

Aviso Para evitar o sobreaquecimento do encaminhador J-SRX Series services gateway, não utilize este equipamento numa área que exceda a temperatura máxima recomendada de 40°C. Para evitar a restrição à circulação de ar, deixe pelo menos um espaço de 15,2 cm à volta das aberturas de ventilação.

¡Atención! Para impedir que un encaminhador de la serie J-SRX Series services gateway se recaliente, no lo haga funcionar en un área en la que se supere la temperatura ambiente máxima recomendada de 40°C. Para impedir la restricción de la entrada de aire, deje un espacio mínimo de 15,2 cm alrededor de las aperturas para ventilación.

Varning! Förhindra att en J-SRX Series services gateway överhettas genom att inte använda den i ett område där den maximalt rekommenderade omgivningstemperaturen på 40°C överskrids. Förhindra att luftcirkulationen inskränks genom att se till att det finns fritt utrymme på minst 15,2 cm omkring ventilationsöppningarna.

Product Disposal Warning



WARNING: Disposal of this product must be handled according to all national laws and regulations.

Waarschuwing Dit produkt dient volgens alle landelijke wetten en voorschriften te worden afgedankt.

Varoitus Tämän tuotteen lopullisesta hävittämisestä tulee huolehtia kaikkia valtakunnallisia lakeja ja säännöksiä noudattaen.

Attention La mise au rebut définitive de ce produit doit être effectuée conformément à toutes les lois et réglementations en vigueur.

Warnung Dieses Produkt muß den geltenden Gesetzen und Vorschriften entsprechend entsorgt werden.

Avvertenza L'eliminazione finale di questo prodotto deve essere eseguita osservando le normative italiane vigenti in materia

Advarsel Endelig disponering av dette produktet må skje i henhold til nasjonale lover og forskrifter.

Aviso A descartagem final deste produto deverá ser efectuada de acordo com os regulamentos e a legislação nacional.

¡Atención! El desecho final de este producto debe realizarse según todas las leyes y regulaciones nacionales

Varning! Slutlig kassering av denna produkt bör skötas i enlighet med landets alla lagar och föreskrifter.

-
- Related Topics**
- J-SRX240 Services Gateway Definition of Safety Warning Levels on page 99
 - J-SRX240 Services Gateway General Safety Guidelines and Warnings on page 101
 - J-SRX240 Services Gateway Fire Safety Requirements on page 105
 - J-SRX240 Services Gateway Installation Safety Guidelines and Warnings on page 106
 - J-SRX240 Services Gateway Laser and LED Safety Guidelines and Warnings on page 110
 - J-SRX240 Services Gateway Electrical Safety Guidelines and Warnings on page 118

J-SRX240 Services Gateway Electrical Safety Guidelines and Warnings

When working on equipment powered by electricity, follow the safety guidelines.

This topic includes the following sections:

- Electrical Safety Guidelines and Warnings on page 118

Electrical Safety Guidelines and Warnings

In Case of Electrical Accident

If an electrical accident results in an injury, take the following actions in this order:

1. Use caution. Be aware of potentially hazardous conditions that could cause further injury.
2. Disconnect power from the services gateway.
3. If possible, send another person to get medical aid. Otherwise, assess the condition of the victim, then call for help.

General Electrical Safety Guidelines and Warnings

- Install the services gateway in compliance with the following local, national, or international electrical codes:
 - United States—National Fire Protection Association (NFPA 70), United States National Electrical Code
 - Canada—Canadian Electrical Code, Part 1, CSA C22.1

- Other countries—International Electromechanical Commission (IEC) 60364, Part 1 through Part 7
- Evaluated to the TN power system
- Locate the emergency power-off switch for the room in which you are working so that if an electrical accident occurs, you can quickly turn off the power.
- Do not work alone if potentially hazardous conditions exist anywhere in your workspace.
- Never assume that power is disconnected from a circuit. Always check the circuit before starting to work.
- Carefully look for possible hazards in your work area, such as moist floors, ungrounded power extension cords, and missing safety grounds.
- Operate the services gateway within marked electrical ratings and product usage instructions.
- For the services gateway and peripheral equipment to function safely and correctly, use the cables and connectors specified for the attached peripheral equipment, and make certain they are in good condition.

Related Topics

- J-SRX240 Services Gateway Definition of Safety Warning Levels on page 99
- J-SRX240 Services Gateway General Safety Guidelines and Warnings on page 101
- J-SRX240 Services Gateway Fire Safety Requirements on page 105
- J-SRX240 Services Gateway Installation Safety Guidelines and Warnings on page 106
- J-SRX240 Services Gateway Laser and LED Safety Guidelines and Warnings on page 110
- J-SRX240 Services Gateway Maintenance and Operational Safety Guidelines and Warnings on page 113

J-SRX240 Services Gateway Agency Approvals

The services gateway complies with the following standards:

- Safety
 - CSA 60950-1 (2003) Safety of Information Technology Equipment
 - UL 60950-1 (2003) Safety of Information Technology Equipment
 - EN 60950-1 (2001) Safety of Information Technology Equipment
 - IEC 60950-1 (2001) Safety of Information Technology Equipment (with country deviations)

- EN 60825-1 +A1+A2 (1994) Safety of Laser Products - Part 1: Equipment Classification
- EN 60825-2 (2000) Safety of Laser Products - Part 2: Safety of Optical Fiber Comm. Systems
- EMC
 - EN 300 386 V1.3.3 (2005) Telecom Network Equipment - EMC requirements
- EMI
 - FCC Part 15 Class A (2007) USA Radiated Emissions
 - EN 55022 Class A (2006) European Radiated Emissions
 - VCCI Class A (2007) Japanese Radiated Emissions
- Immunity
 - EN 55024 +A1+A2 (1998) Information Technology Equipment Immunity Characteristics
 - EN-61000-3-2 (2006) Power Line Harmonics
 - EN-61000-3-3 +A1 +A2 +A3 (1995) Power Line Voltage Fluctuations
 - EN-61000-4-2 +A1 +A2 (1995) Electrostatic Discharge
 - EN-61000-4-3 +A1+A2 (2002) Radiated Immunity
 - EN-61000-4-4 (2004) Electrical Fast Transients
 - EN-61000-4-5 (2006) Surge
 - EN-61000-4-6 (2007) Immunity to Conducted Disturbances
 - EN-61000-4-11 (2004) Voltage Dips and Sags

- Related Topics**
- J-SRX240 Services Gateway Compliance Statements for EMC Requirements on page 120
 - J-SRX240 Services Gateway Compliance Statements for Environmental Requirements on page 121
 - J-SRX240 Services Gateway Compliance Statements for Acoustic Noise on page 122

J-SRX240 Services Gateway Compliance Statements for EMC Requirements

This topic includes the following sections:

- Canada on page 121
- European Community on page 121
- Japan on page 121
- United States on page 121

Canada

This Class A digital apparatus complies with Canadian ICES-003.

Cet appareil numérique de la classe A est conforme à la norme NMB-003 du Canada.

European Community

This is a Class A product. In a domestic environment this product may cause radio interference in which case the user may be required to take adequate measures.

Japan

この装置は、情報処理装置等電波障害自主規制協議会（VCCI）の基準に基づくクラスA 情報技術装置です。この装置は、家庭環境で使用することを目的としていますが、この装置がラジオやテレビジョン受信機に近接して使用されると、受信障害を引き起こすことがあります。
取扱説明書に従って正しい取り扱いをして下さい。

The preceding translates as follows:

This is a Class A product based on the standard of the Voluntary Control Council for Interference by Information Technology Equipment (VCCI). If this product is used near a radio or television receiver in a domestic environment, it may cause radio interference. Install and use the equipment according to the instruction manual.

United States

The services gateway has been tested and found to comply with the limits for a Class A digital device of the FCC Rules. These limits are designed to provide reasonable protection against harmful interference when the equipment is operated in a commercial environment. This equipment generates, uses, and can radiate radio frequency energy and, if not installed and used in accordance with the instruction manual, may cause harmful interference to radio communications. Operation of this equipment in a residential area is likely to cause harmful interference in which case the user will be required to correct the interference at his own expense.

- Related Topics**
- J-SRX240 Services Gateway Compliance Statements for Environmental Requirements on page 121
 - J-SRX240 Services Gateway Agency Approvals on page 119
 - J-SRX240 Services Gateway Compliance Statements for Acoustic Noise on page 122

J-SRX240 Services Gateway Compliance Statements for Environmental Requirements

This topic includes the compliance statement for the following environmental requirement:

Lithium Battery

Batteries in this product are not based on mercury, lead, or cadmium substances. The batteries used in this product are in compliance with EU Directives 91/157/EEC, 93/86/EEC, and 98/101/EEC. The product documentation includes instructional information about the proper method of reclamation and recycling.

- Related Topics**
- J-SRX240 Services Gateway Compliance Statements for EMC Requirements on page 120
 - J-SRX240 Services Gateway Compliance Statements for Acoustic Noise on page 122
 - J-SRX240 Services Gateway Agency Approvals on page 119

J-SRX240 Services Gateway Compliance Statements for Acoustic Noise

Maschinenlärminformations-Verordnung - 3. GPSGV, der höchste Schalldruckpegel beträgt 70 dB(A) oder weniger gemäss EN ISO 7779

Translation:

The maximum emitted sound pressure level is 70 dB(A) or less per EN ISO 7779.

- Related Topics**
- J-SRX240 Services Gateway Compliance Statements for EMC Requirements on page 120
 - J-SRX240 Services Gateway Compliance Statements for Environmental Requirements on page 121
 - J-SRX240 Services Gateway Agency Approvals on page 119

APPENDIX B

J-SRX240 Services Gateway Power Guidelines, Requirements, and Specifications

This appendix includes the following topics:

- J-SRX240 Services Gateway Site Electrical Wiring Guidelines on page 123
- J-SRX240 Services Gateway Power Specifications and Requirements on page 124
- J-SRX240 Services Gateway Grounding Specifications on page 125

J-SRX240 Services Gateway Site Electrical Wiring Guidelines

Table 36 on page 123 describes the factors you must consider while planning the electrical wiring for the services gateway at your site.



CAUTION: It is particularly important to provide a properly grounded and shielded environment and to use electrical surge-suppression devices.

Table 36: Site Electrical Wiring Guidelines for the Services Gateway

Site Wiring Factor	Guideline
Signaling Limitations	<p>To ensure that signaling functions optimally:</p> <ul style="list-style-type: none">• Install wires correctly. Improperly installed wires can emit radio interference.• Do not exceed the recommended distances or pass wires between buildings. The potential for damage from lightning strikes increases if wires exceed recommended distances or if wires pass between buildings.• Shield all conductors. The electromagnetic pulse (EMP) caused by lightning can damage unshielded conductors and destroy electronic devices.

Table 36: Site Electrical Wiring Guidelines for the Services Gateway (continued)

Site Wiring Factor	Guideline
Radio Frequency Interference (RFI)	<p>To reduce or eliminate the emission of RFI from your site wiring:</p> <ul style="list-style-type: none"> • Use twisted-pair cable with a good distribution of grounding conductors. • Use a high-quality twisted-pair cable with one ground conductor for each data signal when applicable, if you must exceed the recommended distances.
Electromagnetic Compatibility (EMC)	<p>Provide a properly grounded and shielded environment and use electrical surge-suppression devices.</p> <p>Strong sources of electromagnetic interference (EMI) can cause the following damage:</p> <ul style="list-style-type: none"> • Destroy the signal drivers and receivers in the device • Conduct power surges over the lines into the equipment, resulting in an electrical hazard <p>NOTE: If your site is susceptible to problems with EMC, particularly from lightning or radio transmitters, you may want to seek expert advice.</p>



CAUTION: To comply with intrabuilding lightning/surge requirements, the intrabuilding wiring must be shielded. The shielding for the wiring must be grounded at both ends.

- Related Topics**
- J-SRX240 Services Gateway Power Specifications and Requirements on page 124
 - J-SRX240 Services Gateway Grounding Specifications on page 125
 - J-SRX240 Services Gateway Power Supply on page 20

J-SRX240 Services Gateway Power Specifications and Requirements

This topic provides details on the power requirement specifications and AC cord specifications for your J-SRX240 Services Gateway.

Power Requirement Specifications

The AC power system electrical specifications for the J-SRX240 Services Gateway are listed in Table 37 on page 124.

Table 37: Power Requirement Specifications for the J-SRX240 Services Gateway

Power Requirement	Specification
AC input voltage	100 to 240 VAC
AC input line frequency	50 to 60 Hz

Table 37: Power Requirement Specifications for the J-SRX240 Services Gateway (continued)

Power Requirement	Specification
AC system current rating	2.5 A 4.5 A (for PoE and media gateway models)

AC Power Cord Specifications

Table 38 on page 125 provides power cord specifications and Table 38 on page 125 depicts the plugs on the AC power cords provided for each country or region.

Table 38: AC Power Cord Specifications

Country	Model Number
Australia	CBL-JX-PWR-AU
China	CBL-JX-PWR-CH
Europe (except Denmark, Italy, Switzerland, and United Kingdom)	CBL-JX-PWR-EU
Italy	CBL-JX-PWR-IT
Japan	CBL-JX-PWR-JP
North America	CBL-JX-PWR-US
United Kingdom	CBL-JX-PWR-UK



WARNING: The AC power cord for the services gateway is intended for use with the device only and not for any other use.

- Related Topics**
- J-SRX240 Services Gateway Site Electrical Wiring Guidelines on page 123
 - J-SRX240 Services Gateway Grounding Specifications on page 125
 - J-SRX240 Services Gateway Power Supply on page 20

J-SRX240 Services Gateway Grounding Specifications

To meet safety and electromagnetic interference (EMI) requirements and to ensure proper operation, the services gateway must be adequately grounded before power is connected. A grounding lug provided on the rear of the services gateway chassis is used to connect the device to earth ground.



WARNING: Before device installation begins, a licensed electrician must attach a cable lug to the grounding and power cables that you supply. A cable with an incorrectly attached lug can damage the device (for example, by causing a short circuit).

To ground the device before connecting power, you connect the grounding cable to earth ground and then attach the lug on the cable to the chassis grounding point with the screw.

Table 39 on page 126 lists the specifications of the grounding cable used with the device.

Table 39: Grounding Cable Specifications for the Services Gateway

Grounding Requirement	Specification
Grounding cable	14 AWG single-strand wire cable
Amperage of grounding cable	Up to 25 A
Grounding lug	Ring-type, vinyl-insulated TV14-6R lug or equivalent

- Related Topics**
- J-SRX240 Services Gateway Site Electrical Wiring Guidelines on page 123
 - Grounding the J-SRX240 Services Gateway on page 57
 - J-SRX240 Services Gateway Power Specifications and Requirements on page 124
 - J-SRX240 Services Gateway Power Supply on page 20

APPENDIX C

J-SRX240 Services Gateway Interface Cable Specifications and Connector Pinouts

This appendix includes the following topics:

- Interface Cable and Wire Specifications for the J-SRX240 Services Gateway on page 127
- RJ-45 Connector Pinouts for the J-SRX240 Services Gateway Ethernet Port on page 128
- RJ-45 Connector Pinouts for the J-SRX240 Services Gateway Console Port on page 128
- RJ-11 Connector Pinouts for the J-SRX240 Services Gateway with Integrated Convergence Services FXO and FXS Ports on page 129

Interface Cable and Wire Specifications for the J-SRX240 Services Gateway

Table 40 on page 127 lists the specifications for the cables that connect to ports.

Table 40: Cable and Wire Specifications for Ports

Port	Cable Specification	Cable/Wire Supplied	Maximum Length	Device Receptacle
Console port	RS-232 (EIA-232) serial cable	One 6-ft (1.83-m) length with DB-9/DB-9 connectors	6 ft (1.83 m)	RJ-45
Ethernet port	Category 5 cable or equivalent suitable for 100BASE-T operation	One 15-ft (4.57-m) length with RJ-45/RJ-45 connectors	328 ft (100 m)	RJ-45

- Related Topics**
- RJ-45 Connector Pinouts for the J-SRX240 Services Gateway Ethernet Port on page 128
 - RJ-45 Connector Pinouts for the J-SRX240 Services Gateway Console Port on page 128
 - RJ-11 Connector Pinouts for the J-SRX240 Services Gateway with Integrated Convergence Services FXO and FXS Ports on page 129

RJ-45 Connector Pinouts for the J-SRX240 Services Gateway Ethernet Port

The Ethernet ports on the front panel are autosensing 10/100-Mbps Ethernet RJ-45 receptacle that accepts an Ethernet cable for connecting the services gateway to a management LAN (or other device that supports out-of-band management).

Figure 16 on page 128 shows the RJ-45 cable connector.

Figure 16: Ethernet Cable Connector (RJ-45)

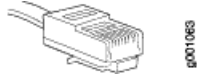

Table 41 on page 128 describes the RJ-45 connector pinouts for the Ethernet port.

Table 41: RJ-45 Connector Pinouts for the Services Gateway Ethernet Port

Pin	Signal
1	TX+
2	TX –
3	RX+
4	Termination network
5	Termination network
6	RXD
7	Termination network
8	Termination network

- Related Topics**
- Interface Cable and Wire Specifications for the J-SRX240 Services Gateway on page 127
 - RJ-45 Connector Pinouts for the J-SRX240 Services Gateway Console Port on page 128
 - RJ-11 Connector Pinouts for the J-SRX240 Services Gateway with Integrated Convergence Services FXO and FXS Ports on page 129

RJ-45 Connector Pinouts for the J-SRX240 Services Gateway Console Port

The port on the front panel labeled console is an autosensing 10/100-Mbps Ethernet RJ-45 receptacle that accepts an RJ-45 cable for connecting the services gateway to a management LAN (or other device that supports out-of-band management).

Figure 17 on page 129 shows the RJ-45 connector pinouts for the console port.

Figure 17: Console Cable Connector

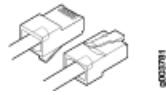

Table 42 on page 129 describes the RJ-45 connector pinouts for the console port.

Table 42: RJ-45 Connector Pinouts for Services Gateway Console Port

Pin	Signal	Description
1	RTS	Request to Send
2	DTR	Data Terminal Ready
3	TXD	Transmit Data
4	Ground	Signal Ground
5	Ground	Signal Ground
6	RXD	Receive Data
7	DSR/DCD	Data Set Ready
8	CTS	Clear to Send

- Related Topics**
- Interface Cable and Wire Specifications for the J-SRX240 Services Gateway on page 127
 - RJ-45 Connector Pinouts for the J-SRX240 Services Gateway Ethernet Port on page 128
 - RJ-11 Connector Pinouts for the J-SRX240 Services Gateway with Integrated Convergence Services FXO and FXS Ports on page 129

RJ-11 Connector Pinouts for the J-SRX240 Services Gateway with Integrated Convergence Services FXO and FXS Ports

The 2-Port FXS and 2-Port FXO ports on the back panel of the J-SRX240 Services Gateway with Integrated Convergence Services use an RJ-11 cable, which is not supplied with the services gateway.

Table 43 on page 129 describes the RJ-45 connector pinouts for the Ethernet port.

Table 43: RJ-11 Connector Pinouts for the Services Gateway Ethernet Port

Pin	Signal
1	No Connect
2	Ring

Table 43: RJ-11 Connector Pinouts for the Services Gateway Ethernet Port (continued)

Pin	Signal
3	Tip
4	No Connect

- Related Topics**
- Interface Cable and Wire Specifications for the J-SRX240 Services Gateway on page 127
 - RJ-45 Connector Pinouts for the J-SRX240 Services Gateway Ethernet Port on page 128
 - RJ-45 Connector Pinouts for the J-SRX240 Services Gateway Console Port on page 128

APPENDIX D

Getting Help

This section contains information about getting help for questions about the PowerConnect J–SRX Series products. The topics covered in this section include:

- Obtaining Assistance on page 131
- Dell Enterprise Training and Certification on page 133
- Problems With Your Order on page 133
- Product Information on page 133
- Returning Items for Warranty Repair or Credit on page 133
- Before You Call on page 134
- Contacting Dell on page 135
- Locating a J-SRX240 Services Gateway Component Serial Number and Agency Labels on page 135
- Packing the J-SRX240 Services Gateway and Components for Shipment on page 136
- Dell Support on page 138

Obtaining Assistance

If you experience a problem with your computer, you can complete the following steps to diagnose and troubleshoot the problem:

1. Fill out the diagnostics checklist. See "Diagnostics Checklist."
2. Use Dell's extensive suite of online services available at Dell Support (<http://www.support.dell.com>) for help with installation and troubleshooting procedures. See "Online Services" for a more extensive list of Dell Support online.
3. If the preceding steps have not resolved the problem, see "Contacting Dell."



NOTE: Call Dell Support from a telephone near or at the computer so that the support staff can assist you with any necessary procedures.



NOTE: Dell's Express Service Code system may not be available in all countries.

When prompted by Dell's automated telephone system, enter your Express Service Code to route the call directly to the proper support personnel. For instructions on using the Dell Support, see "Support Service."



NOTE: Some of the following services are not always available in all locations outside the continental U.S. Call your local Dell representative for information on availability.

Online Services

You can learn about Dell products and services on the following websites:

- <http://www.dell.com>
- <http://www.dell.com/ap> (Asian/Pacific countries only)
- <http://www.dell.com/jp> (Japan only)
- <http://www.euro.dell.com> (Europe only)
- <http://www.dell.com/la> (Latin American and Caribbean countries)
- <http://www.dell.ca> (Canada only)

You can access Dell Support through the following websites and e-mail addresses:

- Dell Support websites
 - <http://www.support.dell.com>
 - <http://www.support.jp.dell.com> (Japan only)
 - <http://www.support.euro.dell.com> (Europe only)
- Dell Support e-mail addresses
 - mobile_support@us.dell.com
 - support@us.dell.com
 - la-techsupport@dell.com (Latin America and Caribbean countries only)
 - apsupport@dell.com (Asian/Pacific countries only)
- Dell Marketing and Sales e-mail addresses
 - apmarketing@dell.com (Asian/Pacific countries only)
 - sales_canada@dell.com (Canada only)
- Anonymous file transfer protocol (FTP)
 - [ftp.dell.com](ftp://ftp.dell.com)

Log in as user: anonymous, and use your e-mail address as your password.

Automated Order-Status Service

To check on the status of any Dell products that you have ordered, you can go to <http://www.support.dell.com>, or you can call the automated order-status service. A recording prompts you for the information needed to locate and report on your order. For the telephone number to call for your region, see "Contacting Dell."

Support Service

Dell's support service is available 24 hours a day, 7 days a week, to answer your questions about Dell hardware. Our support staff use computer-based diagnostics to provide fast, accurate answers. To contact Dell's support service, see "Before You Call" and then see the contact information for your region.

Dell Enterprise Training and Certification

Dell Enterprise Training and Certification is available; see <http://www.dell.com/training> for more information. This service may not be offered in all locations.

Problems With Your Order

If you have a problem with your order, such as missing parts, wrong parts, or incorrect billing, contact Dell for customer assistance. Have your invoice or packing slip handy when you call. For the telephone number to call for your region, see "Contacting Dell."

Product Information

If you need information about additional products available from Dell, or if you would like to place an order, visit the Dell website at <http://www.dell.com>. For the telephone number to call for your region or to speak to a sales specialist, see "Contacting Dell."

Returning Items for Warranty Repair or Credit

Prepare all items being returned, whether for repair or credit, as follows:

1. Call Dell to obtain a Return Material Authorization Number, and write it clearly and prominently on the outside of the box. For the telephone number to call for your region, see "Contacting Dell."
2. Include a copy of the invoice and a letter describing the reason for the return.
3. Include a copy of the Diagnostics Checklist (see "Diagnostics Checklist"), indicating the tests that you have run and any error messages reported by the Dell Diagnostics.
4. Include any accessories that belong with the item(s) being returned (such as power cables, media such as CDs and diskettes, and guides) if the return is for credit.
5. Pack the equipment to be returned in the original (or equivalent) packing materials.

You are responsible for paying shipping expenses. You are also responsible for insuring any product returned, and you assume the risk of loss during shipment to Dell. Collect On Delivery (C.O.D.) packages are not accepted.

Returns that are missing any of the preceding requirements will be refused at Dell's receiving dock and returned to you.

Before You Call



NOTE: Have your Express Service Code ready when you call. The code helps Dell's automated-support telephone system direct your call more efficiently.

Remember to fill out the Diagnostics Checklist (see "Diagnostics Checklist"). If possible, turn on your computer before you call Dell for assistance and call from a telephone at or near the computer. You may be asked to type some commands at the keyboard, relay detailed information during operations, or try other troubleshooting steps possible only at the computer itself. Ensure that the computer documentation is available.



WARNING: Before working inside your device, follow the safety instructions in the Safety, Environmental, and Regulatory Information that shipped with your system.

Diagnostics Checklist

Name:

Date:

Address:

Phone number:

Service Tag (bar code on the back or bottom of the device):

Express Service Code:

Return Material Authorization Number (if provided by Dell support technician):

Operating system and version:

Devices:

Expansion cards:

Are you connected to a network? Yes No

Network, version, and network adapter:

Programs and versions:

See your operating system documentation to determine the contents of the system's start-up files. If the computer is connected to a printer, print each file. Otherwise, record the contents of each file before calling Dell.

Error message, beep code, or diagnostic code:

Description of problem and troubleshooting procedures you performed:

Contacting Dell

For customers in the United States, call 800-WWW.DELL (800.999.3355).



NOTE: If you do not have an active Internet connection, you can find contact information on your purchase invoice, packing slip, bill, or Dell product catalog.

Dell provides several online and telephone-based support and service options. Availability varies by country and product, and some services may not be available in your area. To contact Dell for sales, technical support, or customer service issues:

1. Visit <http://www.support.dell.com>.
2. Click your country or region at the bottom of the page. For a full listing of countries and regions, click **All**.
3. In the Support menu, click **All Support**.
4. Choose the method of contacting Dell that is convenient for you.

Locating a J-SRX240 Services Gateway Component Serial Number and Agency Labels

Before contacting Dell to request an RMA, you must find the serial number and agency label on the J-SRX240 Services Gateway or component.

Listing the J-SRX240 Services Gateway and Component Details with the CLI

To list all of the J-SRX240 Services Gateway components and their serial numbers, enter the following command-line interface (CLI) command:

```
root> show chassis hardware
Hardware inventory:
Item Version Part number Serial number Description
Chassis                AH1111AA7872    Dell J-SRX240h-poe
Routing Engine   R EV 01    750-021794    PW7872    RE-SRX240-POE
FPC 0                                FPC
PIC 0                                16x GE Base PIC

Power Supply 0
```



NOTE: In the `show chassis hardware` command, the Mini-Physical Interface Module (Mini-PIM) slot number is reported as an FPC number, and the Mini-PIM number (always 0) is reported as the PIC number.

Most components also have a serial number ID label attached to the component body.

Chassis Serial Number and Agency Labels

The J-SRX240 Services Gateway has a serial number ID label located on the back of the chassis and an agency label on the bottom of the chassis as shown in Figure 18 on page 136.

Figure 18: Location of J-SRX240 Serial Number and Agency Labels

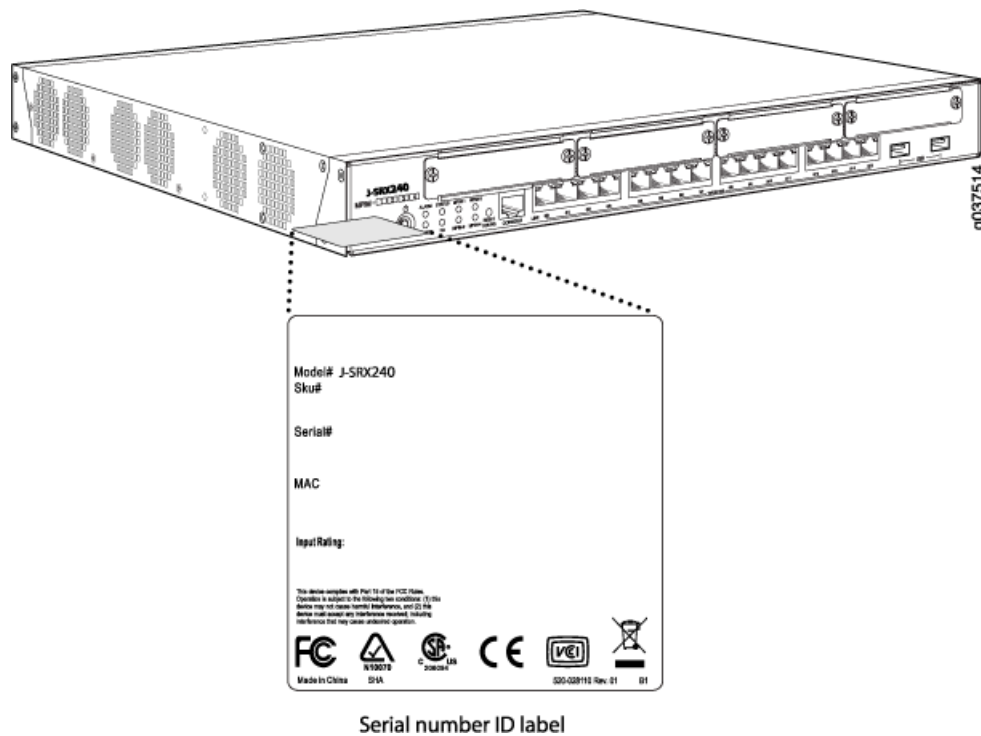

Serial number ID label

Mini-Physical Interface Module Serial Number Label

Mini-Physical Interface Modules (Mini-PIMs) are field-replaceable on the J-SRX240 Services Gateway. Each Mini-PIM has a unique serial number. The serial number label is located on the right side of the Mini-PIM, when the Mini-PIM is horizontally oriented (as it would be installed on the device).

The exact location might be slightly different on different Mini-PIMs, depending on the placement of components on the Mini-PIM.

Packing the J-SRX240 Services Gateway and Components for Shipment

Packing the Services Gateway

To pack the services gateway for shipment:

1. Retrieve the shipping carton and packing materials in which the device was originally shipped. If you do not have these materials, contact your Dell Support representative about approved packaging materials.
2. Attach an electrostatic discharge (ESD) grounding strap to your bare wrist and connect the strap to the ESD point on the chassis or to an outside ESD point if the device is disconnected from earth ground.

3. On the console or other management device connected to the services gateway, enter CLI operational mode and issue the following command to shut down the services gateway software:

```
user@host> request system power-off
```

Wait until a message appears on the console confirming that the operating system has halted.

4. Shut down power to the device by pressing the Power button on the front panel of the device.
5. Disconnect power from the device.
6. Remove the cables that connect to all external devices.
7. Remove all field-replaceable units (FRUs) from the device.
8. If the device is installed on a wall or rack, have one person support the weight of the device while another person unscrews and removes the mounting screws.
9. Place the device in the shipping carton.
10. Cover the device with an ESD bag, and place the packing foam on top of and around the device.
11. Replace the accessory box on top of the packing foam.
12. Securely tape the box closed.
13. Write the Return Materials Authorization (RMA) number on the exterior of the box to ensure proper tracking.

Packing the Components for Shipment

Follow these guidelines for packing and shipping individual components of the services gateway:

- When you return a component, make sure that it is adequately protected with packing materials and packed so that the pieces are prevented from moving around inside the carton.
- Use the original shipping materials if they are available.
- Place individual Mini-Physical Interface Modules (Mini-PIMs) in electrostatic bags.
- Write the Return Materials Authorization (RMA) number on the exterior of the box to ensure proper tracking.



CAUTION: Do not stack any of the services gateway components during packing.

Related Topics

- Required Tools and Parts for Installing and Maintaining the J-SRX240 Services Gateway on page 45
- Locating a J-SRX240 Services Gateway Component Serial Number and Agency Labels on page 135

- J-SRX240 Services Gateway General Safety Guidelines and Warnings on page 101

Dell Support

If you need assistance while troubleshooting a services gateway, please go to the Dell Support website at <http://www.support.dell.com>.

PART 5

Index

- Index on page 141

Index

A

AC input line frequency.....	124
AC input voltage.....	124
AC system current rating.....	124
Accessory Parts List.....	48
acoustic noise.....	122
agency approvals.....	119
agency labels.....	135
airflow	40
Alarm LED.....	15
approvals, agency.....	119
autoinstallation.....	61

B

back panel.....	9
blank faceplate, removing.....	54
boot devices.....	19
building structure.....	39

C

cables,	64
clearance requirements.....	40
Clearance Requirements.....	40
compliance	
EMC requirements.....	120
general standards.....	119
configuration	
services gateway.....	71
connecting	55
connecting to CLI.....	66
locally.....	66
remotely.....	66
Connecting to J-Web.....	63
console port	
RJ-45.....	129
cooling system.....	20
customer support.....	xv
Customer Support.....	131

D

Dell Support.....	96, 131
-------------------	---------

E

electrical and power requirements.....	41
electricity	
safety warnings.....	118
electromagnetic compatibility.....	123
electrostatic discharge damage.....	101
EMC (EMI)	
compliance with requirements.....	120
standards.....	119
Ethernet cable	
connecting the services gateway to a	
management device.....	64
Ethernet cable, connecting.....	64
Ethernet port	
RJ-45.....	128

F

fans.....	20
fire safety specifications.....	105
flange holes.....	39
front panel.....	9

G

Gigabit Ethernet port.....	13
grounding.....	55
cable, amperage.....	126
lug.....	126

H

HA LED.....	15
hardware features.....	4

I

immunity standards.....	119
interface	
installing.....	54
removing.....	54

interfaces.....	13
internal flash.....	19

J

J-SRX240 Services Gateway	
about.....	3
accessing.....	3
grounding	
specifications.....	125
installation.....	52
installation preparation.....	51
maintenance procedures.....	85
models.....	3
monitoring.....	87
Packing.....	136
power	
specifications.....	124
Returning.....	131
Safety Requirements.....	51
Shipment.....	136
troubleshooting.....	87
Unpacking.....	47

L

laser safety guidelines.....	110
LEDs.....	14
safety warnings.....	110
Lithium Battery.....	121

M

maintenance guidelines	
warnings.....	113
Mini-Physical Interface Module.....	23
Mini-PIM.....	13, 23
Mini-PIM LED.....	15
Mini-PIMs	
installing.....	54
removing.....	54
monitoring	
alarm conditions.....	92
CLI.....	87
LEDs.....	89
power system.....	93
mounting brackets.....	39

N

NEBS standards.....	119
---------------------	-----

O

overview	
installation.....	44

P

parts list	
3-prong power cord.....	48
chassis.....	48
DB-9 to RJ-45 adapter	
straight through, 7 feet.....	48
rack mounting kit.....	48
PoE.....	25
classes and power ratings.....	26
configuring.....	26
supported ports.....	25
supported standards.....	25
PoE Status LED.....	17
Port LED	
TX/RX/Link, POE.....	16
port settings.....	68
power.....	55
powering on.....	59
shutting down.....	59
Power LED.....	15
Power over Ethernet.....	25
power supply.....	20

R

rack requirements.....	39
radio frequency interference.....	123
regulatory compliance.....	99
Reset Config button.....	94
Return Materials Authorization.....	131
RMA.....	131
<i>See also</i> Return Materials Authorization	
RS-232 (EIA-232)	127

S

safety.....	99
requirements.....	51
standards.....	119
warning levels.....	99
serial number.....	135
services gateway	
configuration.....	71
power supply.....	59
powering off.....	59
powering on.....	59
specifications.....	8

show chassis alarms.....	87
show chassis environment.....	87
show chassis fpc.....	87
show chassis hardware.....	87
shutdown	
graceful.....	59
immediate.....	59
signaling limitations.....	123
site preparation checklist.....	37
specifications	
fire safety.....	105
standards compliance.....	119
Status LED.....	15
support, technical.....	xv
T	
technical support.....	xv
Tools and Parts.....	45
antistatic mat.....	45
Blank panels.....	45
Electrostatic bag.....	45
ESD wrist strap.....	45
Flat-blade screw-blade screwdriver.....	45
Phillips (+) screwdriver.....	45
socket wrench.....	45
Tie wrap.....	45
TX/RX/Link LED.....	17
U	
Unpacking.....	47
USB port.....	13
USB storage device.....	19
V	
Verifying Received Parts.....	47
Voice Interface LED.....	18
Voice Port	
RJ-11.....	129
W	
warnings	
electrical.....	118
general.....	101
installation.....	106
laser and LED.....	110
maintenance and operational.....	113

